



**Owner's Manual**





*Dear Customer,*

We thank you for having chosen a MASERATI.

This vehicle is the end result of the MASERATI tradition and experience in the design and production of sports, touring and racing cars.

The purpose of this manual is to provide you with an understanding of the equipment, systems and controls in the car and to explain how they work.

In the final section of this manual you will also find instructions for basic maintenance procedures and the complete Scheduled Maintenance plan, which are needed to maintain steady levels of performance, quality and safety. In addition, keep in mind that proper maintenance is an essential factor contributing to the value of the vehicle over time and to protection of the environment.

For Scheduled Maintenance or any other service, simply contact your local **Authorized Maserati Dealer**. Their technical staff has the proper training and equipment to help ensure that all service work is carried out properly and reliably.

For your own safety and the safety of others, we advise you to read this manual carefully before driving the car.

The Owner's Manual is an integral part of the vehicle and therefore it must always be kept on board.

This manual refers to vehicles with two types of transmissions: manual gearbox and electronically controlled "Cambiocorsa" gearbox; therefore, some instructions may vary on the basis of the specific version.

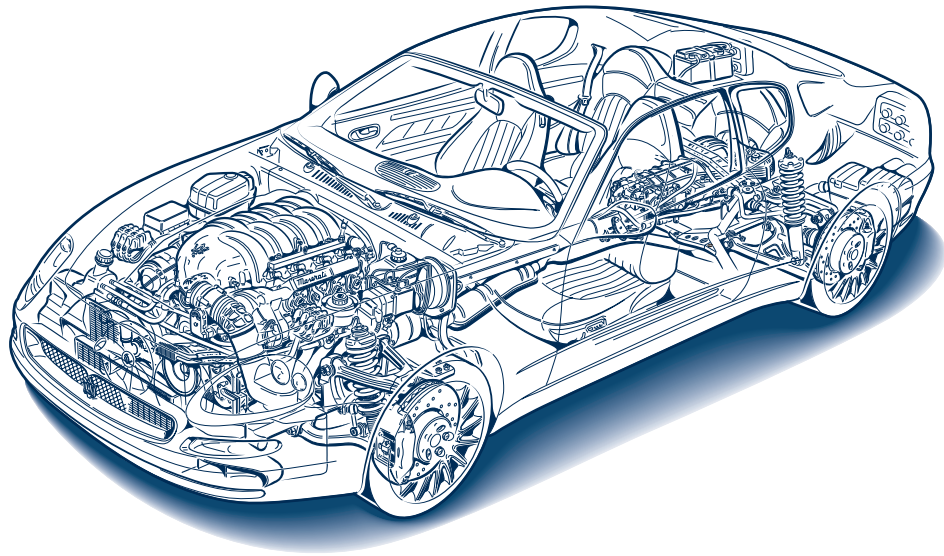



## Historical Background

### 1914

"Alfieri Maserati Garage Workshop" begins its activity in Bologna.

### 1926

Targa Florio, Type 26: debut and victory for the car which carries the Trident emblem on its hood, symbol of Bologna Neptune statue.

### 1927

Emilio Maserati wins the Italian champion title with Type 26.

### 1929

Baconin Borzacchini, Type V4: breaks the world speed 10 km record at 246 km/h.

### 1930

Borzacchini, V4: first victory in a Grand Prix, at Tripoli.

### 1933

Maserati is the first among the European manufacturers to introduce hydraulic brake controls on its racing cars. Giuseppe Campari, with Type 8CM, wins the Grand Prix of France and Tazio Nuvolari the Grand Prix of Belgium and of Nice.

### 1934

Giuseppe Furmanik, Type 4CM: breaks the world speed record for the 1100 class at 222 km/h.

### 1939

Wilbur Shaw with 8CTF wins the Indianapolis 500. Maserati still remains today the first and only Italian manufacturer to have won this legendary track.

### 1940

Maserati moves to Modena.

### 1947

Presentation of the first GT car: the A6 1500, with Pininfarina bodywork. The racing version A6GCS comes out winning with Alberto Ascari on the Modena track.

### 1954

The 250F is victorious in Argentina; this single-seater will enable Maserati to win the Formula 1 World Championship.

### 1957

Fangio wins the world titles with the 250F. At the end of the year Maserati officially retires from racing.

### 1961

The 3500 GT is the first Italian car available with fuel-injection.

### 1963

Creation of Mistral and Quattroporte, then the fastest sedan in the world.

### 1966

Presentation of Ghibli, a coupé designed by Giugiaro.

### 1968

Citrôen joins as a partner, and the V6 engine production is started. Presentation of 2+2 Indy.

### 1971

Presentation of Bora, the first Maserati GT with central engine. Merak will follow a year later.

### 1973

Khamsin, designed by Bertone, replaces Ghibli.

### 1975

Citrôen leaves the company, taken over by Alejandro de Tomaso.

### 1976

The new Quattroporte, designed by Giugiaro, is introduced as a high profile car and will be used even by the President of the Italian Republic.

**1981**

De Tomaso changes strategy and starts producing Biturbo, a sedan with 2 doors with 6-cylinder engine.

**1989**

Shamal is the first car featuring the new Biturbo 8-cylinder with 3200 hp.

**1993**

Fiat Auto purchases remaining shares of Maserati and in 1998 presents the new Quattroporte.

**1997**

Ferrari acquires the control of Maserati.

**1998**

Quattroporte Evoluzione V8 3.2 - V6 2.8.  
3200 GT V8.

**1999**

3200 GT V8 Automatica.

**2000**

The Officine Alfieri Maserati program.

**2002**

Maserati returns to North America.

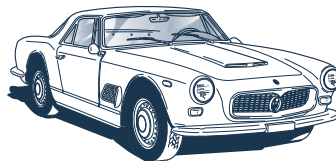

**3500 GT**

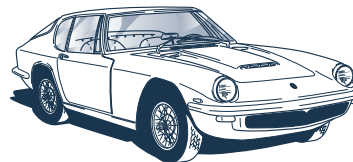

**Mistral coupé**

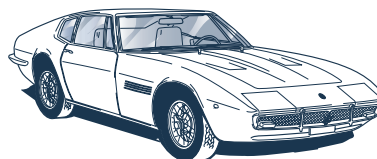

**Ghibli coupé**

*Historical Background*





## Introduction

### Consulting the Manual

To facilitate reading and rapid use, the topics are subdivided into SECTIONS and CHAPTERS.

The important parts requiring particular attention are easily identifiable in the sections and chapters.



**EXTREME CAUTION REQUIRED: non-compliance with the instructions can cause SERIOUS DANGER involving the safety of persons and damage to the vehicle!**

**WARNING:** warning to prevent any damage to the vehicle and thus hazards involving the safety of persons.

### Abbreviations

Some descriptions and terms with particular meanings are found in this manual in an abbreviated form:

**A.C.** - AIR CONDITIONING

**ABS** - ANTILOCK BRAKING SYSTEM - Wheel locking prevention system during braking

**ASR** - ANTI SLIP REGULATION - Prevention of skidding during acceleration

**EBD** - ELECTRONIC BRAKE-FORCE DISTRIBUTION - Electronically-controlled distributor of braking force

**ECU** - ELECTRONIC CONTROL UNIT

**MSP** - MASERATI STABILITY PROGRAM Yaw prevention monitoring system

**"Cambiocorsa"** - Electronically controlled gearbox.

### Updating

The vehicle's high quality level is maintained by constant improvements. Therefore, there may prove to be differences between this manual and your vehicle.

All specifications and illustrations contained in this manual refer to those vehicle specifications as of the printing date, and are subject to change without notice.

### Service

The information contained in this manual is limited to those instructions and indications that are strictly required for the use and maintenance of the vehicle.

The Owner will certainly obtain greater satisfaction and the best performance from the vehicle by following these instructions carefully. We also advise you to have all the maintenance and checking procedures carried out at your **Authorized Maserati Dealer**, as it has properly trained staff and and equipment for your vehicle.

See the Manual entitled "SALES AND SERVICE NETWORK" for locations of AUTHORIZED MASERATI DEALERS.

### "Cambiocorsa" gearbox

The vehicle may be equipped with a mechanical gearbox system with dry double-disc clutch, controlled by an electro-hydraulic system using steering wheel levers.

Although the system can be used in "automatic" mode, the "Cambiocorsa" should not be considered as an automatic transmission. Therefore, for correct use, carefully follow the instructions in the respective section of this manual.

### NHTSA's Toll-free Auto Safety Hotline

If you believe that your vehicle has a defect which could cause a crash, injury or death, you should immediately inform the National Highway Traffic Safety Administration (NHTSA) in addition to notifying Maserati S.p.A. or Maserati North America, Inc.

If NHTSA receives similar complaints, it may open an investigation, and if it finds that a safety defect exists in a group of vehicles, it may order a recall and remedy campaign. However, NHTSA cannot become involved in individual problems between you, your dealer, or Maserati North America, Inc.

To contact NHTSA, you may either call the Auto Safety Hotline toll-free at 1-800-424-9393 (or 1-703-366-0123 in Washington, D.C. area) or write to: NHTSA, U.S. Department of Transportation, Washington, D.C. 20590. You can also obtain other information about motor vehicle safety by calling the Hotline.





## Symbols

There are specific colored plates on or near some of the components on your MASERATI. The related symbols are important warnings that the user must follow when using the particular component.

Symbols included in the labeling on your MASERATI are listed here, along with the component involved with that symbol.

### Danger symbols



**Battery**  
Corrosive liquid.



**Battery**  
Explosion.



**Fan**  
Can start up automatically even with the engine stopped.



**Expansion tank**  
Do not remove the cap when the coolant is hot.



**Coil**  
High voltage.



**Belts and pulleys**  
Moving parts; Keep body parts and clothing away.



**Air-conditioning lines**  
Do not open. Gas under high pressure.

### Symbols of prohibitions



**Battery**  
Do not approach with open flames.



**Battery**  
Keep children at a safe distance.



**Heat guards - belts - pulleys - fans**  
Do not rest your hands on it.

### Warning symbols



#### **Catalytic muffler**

Do not park or stop over flammable surfaces. Refer to section: "Pollution control devices".



#### **Hydraulic steering**

Do not exceed the maximum level of fluid in the tank. Only use lubricants of the type prescribed in the chapter "Capacities and technical specifications".



#### **Brake circuit**

Do not exceed the maximum level of fluid in the tank. Only use fluids of the type prescribed in the chapter "Capacities and technical specifications".



#### **Windshield wiper**

Only use fluids of the type prescribed in the chapter "Capacities and technical specifications".



#### **Engine**

Only use lubricants of the type prescribed in the chapter "Capacities and technical specifications".



#### **Vehicle using lead-free gasoline**

Only use lead-free gasoline with an octane number (R.O.N.) of no less than 93.



#### **Expansion tank**

Only use fluid of the type prescribed in the chapter "Capacities and Technical Specifications".

### Symbols indicating compulsory measures



#### **Battery**

Protect your eyes.



#### **Battery - Jack**

Refer to the Owner's Manual.





## General contents



Car identification data	1
Active and passive safety	2
Instruments and controls	3
Before you drive	4
Using the vehicle	5
In an emergency	6
Capacities and technical specifications	7
Maintenance	8
Contents	9



## Car identification data

Identification plates	14
Homologation plates	15
Instructions plates	17
Key codes	18
Electronic alarm device code	19





## Homologation plates

– V.I.N. plate;

– Plate for compliance with safety standards;

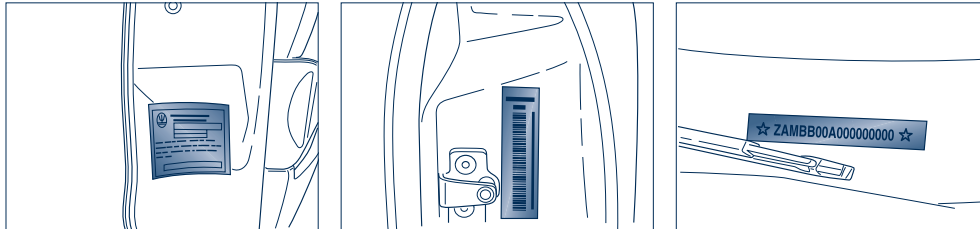

Homologation plates





– Emission control data plate.

1

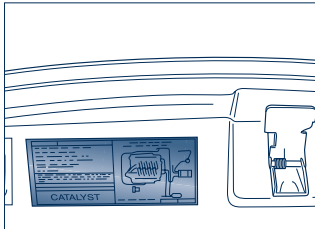

16

*Homologation plates*

## Instructions plates

– Lubricant plate.

– Tire specification plate;

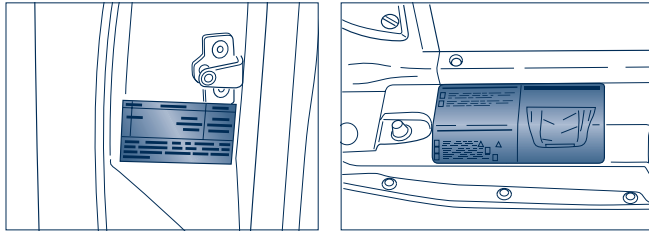



1

## Key codes

A CODE CARD is supplied with the keys. This card indicates the following:

- the electronic code **A** to be used for "emergency starting";
- the mechanical code **B** for the keys, to be given to your **Authorized Maserati Dealer** in the case that you request duplicates of the keys.

**WARNING:** The code numbers shown on the CODE CARD must be kept in a safe place.

**WARNING:** You are advised to always keep the CODE CARD number with you, because it is absolutely necessary in the event of "emergency starting" (see on page 144).

**WARNING:** In the event of a vehicle ownership transfer, it is essential that the new owner is provided with all the keys and the CODE CARD.

**WARNING:** It is advisable to write down and keep the codes listed on the plates delivered with the keys and the remote control in a safe place (not in the car) in order to request duplicates if needed.

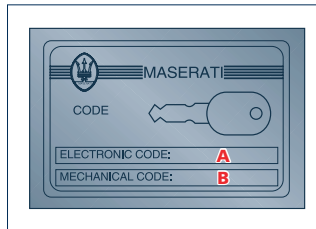

18

Key codes

## Electronic alarm device code

### Rolling Code

Each time the radio operated control is used, the code changes. Keep the plate with the Rolling Code with care and in a safe place. To order extra keys fitted with radio operated controls, contact your **Authorized Maserati Dealer** indicating your complete Rolling Code.

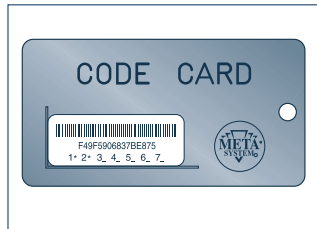

Electronic alarm device code





## Active and passive safety

Seat belts	22
Proper transport of children	27
Front and side airbags	29
MSP System	34
ABS and EBD systems	35
ASR system (electronic anti-skid device)	37
Parking sensors (optional)	38
Fire extinguisher (optional)	41
Fuel cut-off inertia switch	42





## Seat belts

The vehicle is equipped with seat belts with automatic retractors for maximum freedom of movement. The seat belts are equipped with electronically-operated pretensioners and the lower attachments points are connected directly to the seat, to help provide maximum protection whatever the seat position. The passenger seat belt is fitted with the KISI system, which improves safety when children are travelling in special child seats. The system is activated by pulling out the belt to its full length: once the child seat is securely fastened, the belt can no longer be pulled out and hence the belt/child seat system is exceptionally secure. When the belt is released and fully retracted, the system deactivates and resumes its normal operation.



**No child under 12 should travel in the front passenger seat.**

### Fastening the seat belts

After recovering the lower part of the seat belt from the external side of the seat, grasp the connection tab to fasten the belt **A** and pull the seat belt out until the tab is fully inserted in the buckle **B**.

The belt is correctly engaged when the lock clicks into position. Press the button **C** to release the seat belts. If the driver's seat belt is not fastened, when the ignition key is rotated into position **MAR**, the  warning light on the instrument panel will switch on and a buzzer will activate for approximately 8 seconds.

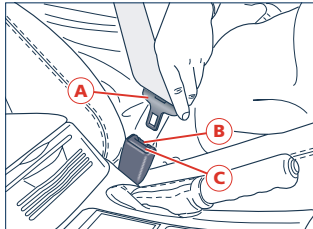

The retractor locking device is designed to activate whenever the belt is pulled out too rapidly or in case of sudden braking or collision.

If the belt locks due to too rapid extraction, allow it to retract a short distance to disengage the locking device.

The retractor allows the belt to automatically fit to the passenger's body, allowing him to move freely. When the vehicle is parked on a steep slope, the retractor may lock: this is normal.

**WARNING: Feed the belt back into the retractor by hand to avoid twisting and snagging.**

### Front seat belt height adjustment

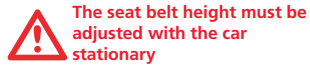

Always adjust the height of the front seat belts in relation to the height of the driver and the passenger. This precaution can help to substantially reduce the risk of injury in the event of a collision. The belt is correctly adjusted when it passes about halfway between the neck and the shoulder. The seat belt upper anchoring point comes equipped with a swinging ring which can be moved in 4 different positions, allowing the height of the seat belts to be adjusted.

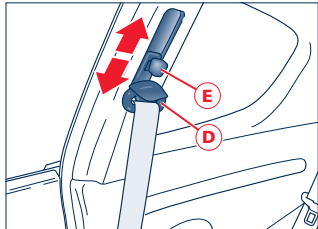

To raise the anchoring point grip ring D directly; to move the anchoring point downwards use handle E.

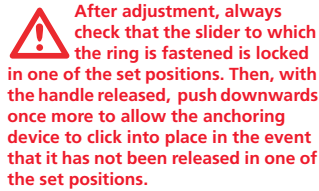

### Load limiting devices

To help increase passive safety, the front seat belt retractors are equipped with a load limiting device which is designed to make it possible to control the belt reeling out so that the force exerted on the shoulders while the seat belt is in restraining mode can be limited.

### Pretensioners

To help make the front seat belts still more efficient, the vehicle is equipped with pretensioners.

These devices "are notified" by a sensor that the vehicle is in a collision and retract the belts slightly. This helps ensure that the belts adhere to the occupants' bodies before they brake their forward motion.

When the belt locks, this indicates that the pretensioners have been activated; a small amount of smoke may be visible.

The smoke is not toxic and is not indicative of fire.

Following the pretensioner activation, the seat belt can be normally released by pressing the button on the buckle.





The pretensioners do not require maintenance or lubrication. Tampering with the devices will compromise their efficient operation. If, as a result of exceptional natural circumstances (floods, heavy seas, etc.), the device has been in contact with water and or sludge, it is absolutely essential to replace it. To ensure the best protection from the pretensioners, secure the belt snugly across your chest and pelvis.



**The pretensioners will operate only once, and will operate even if the belts are not fastened. Therefore, they must be replaced by your Authorized Maserati Dealer after they are activated. The units have a ten year service life from the date of manufacture; they must be replaced when their service life is near expiration.**

**WARNING:** Work on the vehicle which involves blows, vibrations or localized heating (over 212 °F - 100 °C for 6 hours) in the area of the pretensioners may damage or activate them: vibrations due to bad road surfaces or mounting the pavement, for instance, should not affect the units. Please contact your **Authorized Maserati Dealer** if service must be carried out.



**Do not tamper with the pretensioner components. Any intervention must be carried out only by qualified and authorized personnel. Always contact your Authorized Maserati Dealer.**

### Use of the rear seat belts

The rear seat belts must be fastened as shown in the figure.



**Remember that, in the event of a violent collision, passengers in the back seat who are not wearing seat belts not only take a serious personal risk but are also a danger to passengers in the front seats.**

Wear the seat belts with your back in an upright position and leaning against the seatback. When the back seats are not occupied, fasten the seat belt buckles into their relative seats.

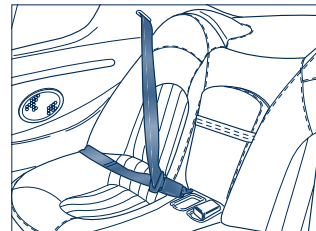

### General warnings regarding the seat belts



The driver is obligated by law to respect and enforce the provisions of local legislation regarding the compulsory use of seat belts.



To help provide maximum protection, you are advised to keep the seatback in the most upright position possible and the seat belt close to your chest and pelvis. If the seat belt is loose, in the event of an accident you could move too far forward and could be injured. Travelling with the seatback too far reclined could also be dangerous: even if the seat belts are fastened, they may not work correctly. In fact, the belt itself may not be close enough to your body and, if it is in front of you, it could cause injuries in an accident. Also, in an accident, the lower section of the belt could press against the upper part of your stomach rather than the pelvic area, causing serious internal injuries.



Always fasten the seat belts. Traveling without the seat belts fastened increases the risk of injury in the event of a collision, even with the airbags, as airbags are designed only to provide supplementary protection. In the event of a collision, the seat belts are designed to help reduce the possibility of the vehicle's occupants being thrown against the parts of the passenger compartment or out of the vehicle. The airbags are designed to work together with the seat belts, not to substitute them. The front airbags only intervene in the event of certain head-on collisions of medium or high intensity; They will not be activated if the vehicle rolls over, or in the event of rear or low intensity frontal collisions, or front angular collisions.



Do not fasten your seat belt using the buckle for the other seat: in the event of an accident, the lower section of the belt could press against the upper part of your stomach rather than the pelvic area and cause you serious internal injuries.



It is extremely dangerous to travel with the belt positioned underneath your arm. In the event of an accident you could be thrown forward and could suffer head, neck, and other injuries. Also, if the belt presses against your ribs, it could cause serious internal injuries.



The belt itself must not be twisted. In an accident, the restraining force would not be distributed evenly across the belt and could consequently cause injuries. Make sure that it is snugly fitted to the occupants' bodies. The upper section of the belt must be correctly fitted in the seat guide and pass over the shoulder and diagonally over the chest. The lower section must be adhere to your pelvis, not the stomach, to avoid sliding forward in case of collision. Do not use devices (clamps, fasteners etc.) to hold the seat belts away from the passengers' bodies.





**Do not carry children on a passenger's lap. Children must be seated in their own seat.**



**If the seat belt has been subjected to strong mechanical stress, for example during a collision, it must be completely replaced together with its anchorages, the anchor point screws and the pretensioner. In fact, even if there are no visible defects, the seat belt could have lost some of its resistance.**



**Pregnant women must always observe local legislation regarding the use of seat belts. Make sure in any case that the lower section of the belt is secured well down on the hips, below the abdominal region of the body.**

#### **Proper use of the seat belts**

- 1) Always use the seat belts with the belt completely flat, not twisted; Make sure the belt can move freely and is not obstructed by anything.**
- 2) The seat belts must be replaced any time the pretensioners are activated or whenever the belt is clearly damaged or worn.**
- 3) Wash the seat belts by hand using water and Ph neutral soap, rinse them and allow them to dry in the shade. Do not use strong detergents, bleaches, colorants or other chemicals which may weaken the belt fabric.**
- 4) Make sure the retractors do not get wet: they are designed to work correctly only if kept dry.**

## Proper transport of children

For the best protection in the event of a collision, all the vehicle's occupants must travel seated and protected by all the suitable restraining systems. The seat belts are designed to be used by persons whose physical characteristics (age, height, weight) are provided for by established legislation in each country. Anyone who does not comply with these provisions may not travel in the passenger seat. This also applies to children. Their heads are proportionally heavier and larger than those of adults, while their bones and muscles are relatively undeveloped. For children to be restrained correctly in the event of a collision, suitable restraining or safety systems must be used.



**No child under 12 should travel in the front passenger seat.**



**We recommend to carry children using suitable child-restraint systems and always in the back seat, as this is the most protected position in the event of a collision.**



**Children must never travel seated on a passenger's lap. A child weighs very little until a collision occurs! In a collision, a child becomes so heavy it is impossible to hold onto him or her. For example, in a collision at only 25 mph (40 km/h), a child weighing 12 lb (5.5 kg) exerts a force of 240 lb (110 kg) against the arms of the person holding him or her. Children must always be protected by a suitable restraining system when travelling.**



**Children who are resting on the airbag or are too close to it when it is activated, may be seriously injured. The airbags and pretensioners offer suitable protection for adults and teenagers, but not for children and babies. Neither the seat belts or the airbags are designed for them.**



**A child traveling in a rearward-facing seat could be seriously injured by an airbag being activated. This could happen because the seat back of the child's seat may be positioned extremely close to the airbag at the moment it is inflated.**



**The structure of a child's body is completely different from adult's or a teenager's (who the seat belts are designed for). A child's hips are so small that seat belt will not stay in the correct position on them. The belt may rise up on the child's stomach and, in the event of a collision, cause serious internal injuries.**





The vehicle is equipped with three anchorage points (two lower and an upper one) for child seats, as provided by the country regulations.

2



**The vehicle is not provided with a manual deactivation switch for the passenger side airbag; it is prohibited to carry children on a rearward facing child-seat mounted on the passenger seat. This regulation is also indicated on the plates attached on the visors and inside the glove compartment.**

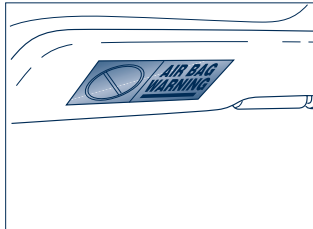

28

*Proper transport of children*

## Front and side airbags

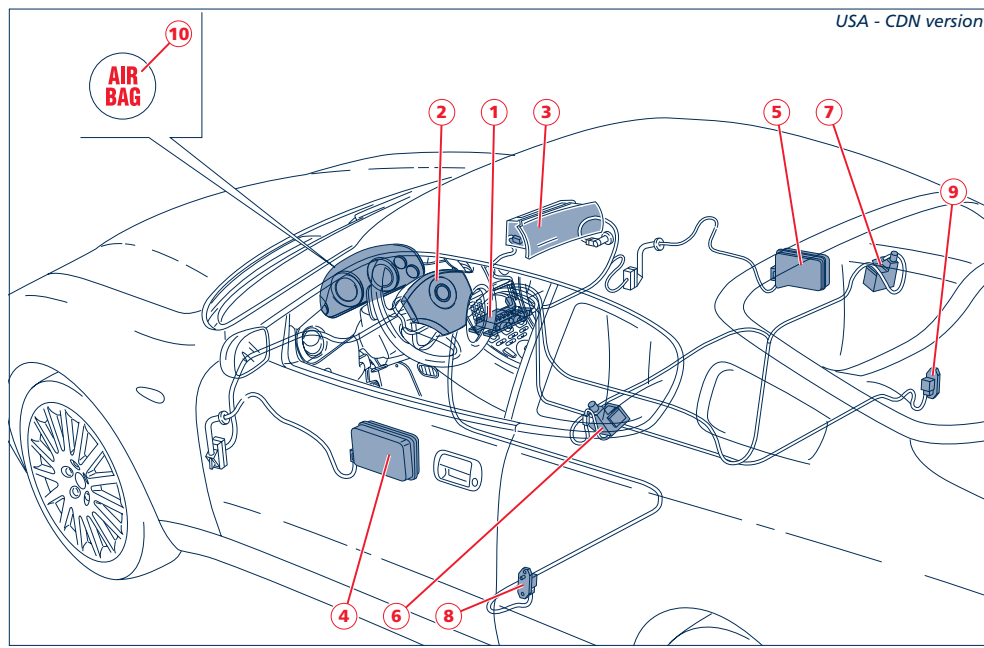

Front and side airbags





The vehicle is equipped with 4 airbags (2 front and 2 side) and electronically-controlled pre-tensioners for the front seat belts.

The system components connected to the ECU are as follows:

- 1) Electronic Control Unit
- 2) Driver's frontal airbag
- 3) Passenger's frontal airbag
- 4) Driver's side airbag
- 5) Passenger's side airbag
- 6) Front left-hand seat belt pretensioner
- 7) Front right-hand seat belt pretensioner
- 8) Left-hand satellite sensor
- 9) Right-hand satellite sensor
- 10) Air bag system failure warning light

### Front airbags

The frontal airbags (for the driver and passenger) are safety devices which are designed to intervene in the event of certain head-on collisions.

It consists of an almost instantaneously inflating bag contained in a special housing:

- in the center of the steering wheel on the driver side;
- in the dashboard and with a larger size bag on the passenger side.

The frontal airbags (for the driver and passenger) are safety devices designed to help protect the occupants in the event of a medium or high intensity head-on collision, which act by placing a cushion (bag) between the occupant and the steering wheel or the instrument panel dashboard.

In the event of such a collision, an ECU is designed to process signals from a deceleration sensor and trigger, the inflation of the bag.

The bag inflates almost instantaneously between the front passengers and potentially harmful structures. The bag deflates immediately afterwards.



**In the event of a collision, anyone not wearing a seat belt will be thrown forward and will come into contact with the bag before it is fully inflated. This reduces the protection offered by the bag. That the front airbags (driver and passenger side) do not replace or substitute the seat belts but supplement them, and hence the seat belts must always be worn as provided by established legislation in most states and other parts of the world.**



**Remember that, in the event of a violent collision, passengers in the back seat who are not wearing seat belts not only take a serious personal risk but are also a danger to passengers in the front seats.**

In case of a low impact head on collision (in which the retaining action of the seat belts affords adequate protection), or front angular collisions, the airbags do not inflate. In case of a rear collision (e.g., impact from behind by another vehicle) or the airbags do not inflate as they do not offer any additional protection. Therefore the bag's failure to engage in these cases is not an indication of a system malfunction.

#### **Passenger side airbag**

The passenger side airbag is designed to afford supplementary protection to a person wearing the seat belt. It is larger than the driver's side airbag to fill the larger part of the space between the occupant and the dashboard.

#### **Side airbags (side bags)**

The side airbags are designed to help provide better protection for those in the front seats in the event of certain moderate to severe side-on collisions. They consist of almost instantaneously inflating bags housed in the door panels.

In case of a lateral collision, the electronic control unit processes the signals from the two satellite sensors mounted near to the rear wheelhouse to determine the local acceleration and it activates the side air bag if necessary. The side bag inflates by bursting through the special seam in the door knob.

The bag inflates instantaneously between the passenger body and the door. It then deflates immediately. In case of low impact lateral collisions (for which the retaining action of the seat belts affords adequate protection), the airbags are designed to not inflate.

It follows that the side airbags do not replace or substitute the seat belts but supplement them, and hence the seat belts must always be worn as provided by established legislation and in most state and other parts of the world.

**WARNING:** The front and/or side airbags may inflate if the vehicle suffers a violent impact beneath the car body, for example when hitting curbs, colliding with steps or speed bumps, potholes etc.

**WARNING:** Airbag inflation releases a small amount of powder. This powder is not harmful and does not indicate the presence of fire. Also, the surface of the deployed bag and the interior of the vehicle may be covered with a powdery residue: this powder may irritate skin and eyes. If contact occurs, wash with a pH neutral soap and water.







 If the **AIR BAG** warning light switches on when the vehicle is running (indicating a fault), contact your Authorized Maserati Dealer as soon as possible to have the system checked.

WARNING: The airbag system has a service life of ten years. When this expiration date is approaching, contact your Authorized Maserati Dealer.

 In case of a collision with consequent airbag deployment, contact your Authorized Maserati Dealer for replacement of the entire safety system, electronic control unit, seat belts, pretensioners, and to have the vehicle's electrical system checked.

 All testing, repairs and replacement of the airbag system must be done by your Authorized Maserati Dealer.

 Never remove the steering wheel. This operation, when needed, must be performed only by authorized personnel of your Authorized Maserati Dealer.

WARNING: To scrap the vehicle, please contact your Authorized Maserati Dealer to have the system deactivated.

If the vehicle is sold, the new owner must be informed of how to use the vehicle and of the aforesaid warnings and he must also be given the Owner's Manual.

 The electronic control unit activates the pretensioners and front/side airbags on the basis of different criteria according to the type of collision. The fact that one or the other system do not activate is not indicative of system malfunction.

### General warnings

 When the ignition key is rotated to the MAR position the **AIR BAG** warning light switches on, but it should switch off after approximately 5 seconds. If the light fails to come on at this time, or stays on, or lights up when driving, contact your Authorized Maserati Dealer immediately.

 Drive with both hands on the steering wheel so that if the airbag inflates it can do so freely without encountering obstacles which can cause serious injuries. Do not drive with the body curved forward but keep the seat back upright to support your back.

 Do not apply stickers or other objects to the steering wheel or the passenger side airbag housing.

 Do not travel with objects in your lap or in front of your chest a pipe, pencil or other object held in your mouth; in the event of a collision, the deployment of the airbag could result in serious injury.

 Note that with the ignition key inserted and turned to the MAR position, even with the engine switched off, the airbags can inflate even if the vehicle is stationary, if it is run into by another vehicle. Thus, even with the vehicle stationary, occupants should be belted in their seats. On the other hand, the airbags will not inflate in case of collision with the vehicle stationary if the key is not inserted and turned; failure of the airbags to inflate in these circumstances is not indicative of system malfunction.

 If the vehicle has been the object of theft or attempted theft, if it has been vandalized or involved in flooding, contact your Authorized Maserati Dealer to have the vehicle and the airbag system checked.

 If service is carried out on the electrical system incorrectly, the airbag could be activated, thereby causing injuries to anyone in the vicinity.

 The airbags do not replace the seat belts but afford supplementary protection. Furthermore, in case of low impact head-on, rear impact, or roll-overs, the passengers are protected exclusively by the seat belts, which must always be secured.

 Do not wash the internal door panels with water or pressurized vapor.





## MSP System

The vehicle is equipped with an **MSP** (Maserati Stability Program) yaw prevention monitoring system encompassing all of the vehicle's control systems: ABS, EBD, ASR and MSR. It has a model within it that predicts the vehicle's behaviour with extreme accuracy. The system is designed to detect whether the driver is about to lose control of the vehicle. In this case, it can activate the brake calipers individually and engine control, in order to create a torque sufficient to resist the vehicle's yawing moment.

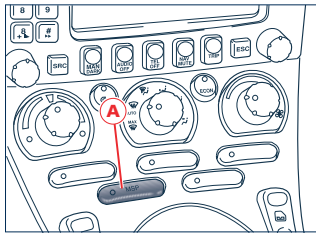

MSP System

### Activating the MSP system

The **MSP** system is automatically enabled each time the engine is started. During the activation phases, the initials **MSP** switch on in green on the multi-function display. To disable it, press button **A** for about 2 seconds. When the system is disabled, the **MSR** initials, on the multi-function display and the LED on the button light up. Press button **A** to switch on the system again: the warning light on the multi-function display and the button led go off.

### Fault signals

In the event of a fault, the system is automatically disabled and cannot be re-activated. When driving, this condition is signalled by the LED on the button switching off and by the **MSR** initials lighting up on the multi-function display. When the engine is started, any system malfunction is signalled by the **MSR** initials lighting up on the multi-function display.

**WARNING** In the event of a malfunction with the **MSP** disabled, the vehicle will react as if it were not equipped with this system. In any case, have the **MSP** system checked at the **Maserati Service Network** as soon as possible.

**WARNING** If you have to tow the car with 2 wheels raised, ensure that the ignition key is in the **STOP** position. Otherwise, with the **MSP** switched on, the respective control unit stores a malfunction in the memory resulting in the **MSR** initials lighting up on the instrument panel, which requires the intervention of the **Maserati Service Network** for resetting of the system.

**WARNING** In low grip conditions (when there is ice, snow, sand etc.) It is advisable **not to** use the **SPORT** mode function, even with the **MSP** enabled.

## ABS and EBD systems

The vehicle is equipped with ABS (Antilock-Braking System) and EBD (Electronic Brakeforce Distribution) systems which, via the ECU and the ABS sensors, help increase the braking system's performance.

In the event of an emergency stop or braking on slippery surfaces (where there is snow, ice, etc.), the ABS, together with the conventional braking system, are designed to allow the driver to apply maximum braking force without the wheels locking and the driver consequently losing control of the vehicle.

The system is based on an ECU which processes the signals transmitted by the 4 sensors located on the 4 wheels. When a wheel is tending to lock, the sensor warns the ECU which, in turn, informs to the electro-hydraulic unit to intervene by modulating the pressure exerted on the brake calipers. The driver will feel a "pulsing" sensation coming from the brake pedal, which is normal.

In the event of a failure, the system will be deactivated, but this will not affect the efficiency of the standard braking system.

The failure is indicated by the red warning ABS  switching on on the instrument panel.

In this case, we recommend you contact the nearest **Authorized Maserati Dealer**, which, thanks to the self-diagnostics system the vehicle is equipped with, should be able to identify the problem.



**The vehicles must be fitted with wheel rims, tires and brake lining of the kind and make approved for this model by the manufacturer.**



**Although this device contributes greatly to the vehicle's safety, it is still essential to drive with particular care, especially when the road is wet or there is snow or ice on the road.**



**The vehicle is equipped with the EBD (Electronic Brakeforce Distribution) system. If the warning light  switches on when the engine is running, this indicates a malfunction in the EBD system; in this case sharp braking could lead to the rear wheels locking too early, and the vehicle may skid. Driving extremely carefully, go directly to the nearest Authorized Maserati Dealer to have the system checked.**





**If only the  warning light switches on while the engine is running, this normally indicates a malfunction in the ABS only. In this case, the braking system maintains its efficiency, but the anti-locking device cannot be used. In these conditions the EBD system may also function less efficiently. Also, in this case we recommend you go to your Authorized Maserati Dealer as soon as possible to have the system checked, avoiding any sharp braking while you drive.**





 If the minimum brake fluid level warning light "BRAKE" switches on, stop the vehicle immediately and check the brake fluid level in the tank: if the level is below the minimum, top it up with the prescribed fluid and contact your Authorized Maserati Dealer to have the system checked. In fact, any fluid leaks from the hydraulic system will jeopardize the operation of both the standard braking and the ABS systems.

 The system's performance, in terms of active safety, must not lead the driver to take unnecessary futile and unjustified risks. The vehicle must always be driven suitably with regard to the weather and road conditions, visibility and the traffic.

 The maximum deceleration that can be reached always depends on the tires' grip on the road. Obviously, if there is snow or ice on the road, the grip is greatly reduced and therefore, in these conditions the braking distance is greater, even with the activation of the ABS system.

### ASR system (electronic anti-skid device)

The ASR system helps prevent the driving wheels from skidding during acceleration via the engine's ECU action (delayed spark advance, reduced engine supply throttle opening and injection cut-off), and that of the rear brakes.

The ASR's action helps to increase the stability and the vehicle's active safety when it is running, especially in the following situations:

- internal wheel skidding on curves because of the dynamic variations of the load or excessive acceleration
- excessive power transmitted to the wheels, also in relation to road conditions
- acceleration on slippery surfaces or where there is snow or ice,
- in the event of loss of grip on wet roads (aquaplaning).

The ASR acts in combination with the electronic suspension adjustment system: in normal conditions (SPORT mode disabled) stability is prioritized in low and medium grip conditions, while with the SPORT mode enabled the system gives priority to the traction, optimizing the vehicle's performance.

### MSR function (engine braking torque adjustment)

The ASR system also helps control the engine braking torque when the accelerator pedal is released under low grip conditions (snow, ice etc.): in these conditions, in fact, the engine's high braking torque may cause instability of the vehicle.

The system, using the same sensors as the ABS, detects the skidding from one or both of the driving wheels when the accelerator is released and opens the engine supply motorized throttle, thereby reducing the braking torque and restoring the driving wheels' maximum grip conditions.

**WARNING:** The maximum deceleration that can be obtained with the engine brake still depends on the tire grip on the road. Obviously, snow or ice on the road greatly reduce the grip values.





## **Parking sensors (optional)**

During parking maneuvers, the parking sensors provide the driver with information on the distance between obstacles found behind the vehicle. The information on the presence and distance of the obstacle is transmitted to the driver by warning beeps which sound with an increasing frequency as the vehicle approaches the obstacle. By supplementing his/her direct visual information with that provided by the system's warning sound signals, the driver may avoid potential collisions.



**However, the driver remains responsible during parking maneuvers and in other potentially dangerous situations. The system has actually been designed only as a supplementary aid during parking maneuvers, since it helps the driver to detect objects outside the field of vision.**

The parking system sensors, housed in the rear bumper, are activated automatically when the key is turned to the **MAR** position and the reverse gear is engaged. When the reverse gear is engaged, a beep warns the driver that the system is active. The system then begins to beep as soon as an obstruction is detected, with the frequency increasing as the vehicle approaches the obstacle. When the obstacle is located at a distance of less than 12 in (30 cm), the beep is continuous.

The warning beep stops immediately if the distance between the vehicle and the obstacle increases. The tone cycle is constant if the distance measured by the central sensors remains unaltered, while if this occurs with the lateral sensors, the signal stops after approximately 3 seconds, to prevent for example continuous beeps in the event of maneuvers alongside walls.

### **Sensors**

To detect the distance of the obstacles, the system uses 4 sensors housed in the rear bumper.



**For the system to operate correctly the sensors positioned on the bumper must be kept clean (remove any mud, dirt, snow or ice).**

**WARNING:** When cleaning the sensors, take special care not to scratch or damage them. Do not use dry, rough or hard cloths. The sensors must be washed with clean water, possibly with car shampoo added. In car-washes which use steam jet or high pressure cleaning machines, keep the nozzle at least 4 in (10 cm) away from the sensors.

### Sensor range

The sensors allow the system to monitor the rear of the vehicle; in fact, their position covers the central and lateral zones at the rear of the vehicle.

If there is an object located in the central zone, it will be detected at distances of less than 1.64 yd (1.50 m). If the obstacle is located in a lateral position, it will be detected at distances of less than 24 in (0.6 m).

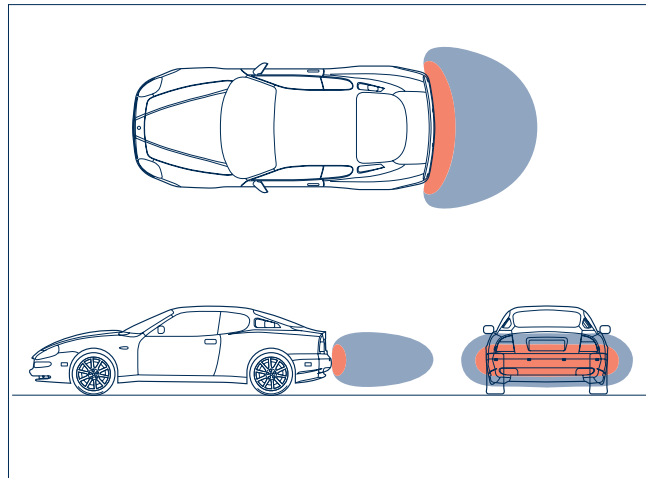
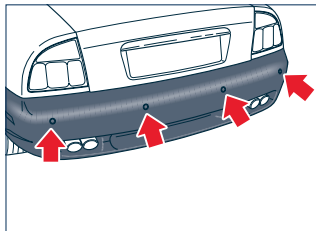

*Parking sensors (optional)*





### Fault signals

The system's ECU runs all the checks on the components every time the reverse gear is engaged.

A parking sensor system failure is indicated by a continuous warning signal from the buzzer when the reverse gear is engaged.

In the event of a failure signal, stop the vehicle and rotate the ignition key to the **STOP** position. Then try cleaning the sensors or moving the vehicle away from any possible ultrasound sources (e.g., pneumatic truck brakes or pneumatic hammers) and rotate the ignition key to the **MAR** position. This way, if the cause of the operating fault has been removed, the system will start functioning again automatically and the failure buzzer will stop.

If however, the failure beep continues, contact your **Authorized Maserati Dealer** to have the system checked.

**WARNING:** During parking maneuvers, always take the utmost care with obstacles that could be located above or underneath the sensors. In fact, in certain circumstances, objects located near the rear of the vehicle may not be detected by the system and therefore could damage the vehicle or be damaged themselves.

**WARNING:** The signals transmitted by the sensors can also be altered by damage to the sensors or by dirt, snow or ice on the latter or even by ultrasound systems (e.g. pneumatic truck brakes or pneumatic hammers) in the vicinity.



**The driver remains responsible during parking maneuvers and in other potentially dangerous situations. When these maneuvers are performed, always make sure there are no people (especially children) or animals in the maneuvering area. The parking sensors are only a supplementary aid for the driver.**

### Fire extinguisher (optional)

A portable fire extinguisher is located on the passenger compartment floor for immediate accessibility in case of need. The extinguisher is fastened by means of special brackets. Charged with powder, it has a 4.4 lb (2 kg) capacity (8 second nominal discharge time) and does not contain chlorofluorocarbons. Check the pressure and the charge status using the pressure gauge **A** regularly.

The fire extinguisher must always be fastened to its special brackets. If it is not used, we recommend you remove the entire device to free the passenger foot area from the fire extinguisher brackets.

**WARNING:** To use the fire extinguisher, follow the specific instructions indicated on the device.

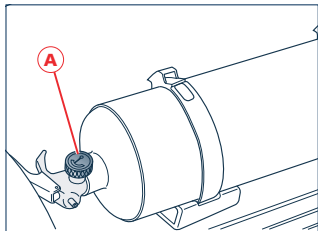

*Fire extinguisher (optional)*





2

## Fuel cut-off inertia switch

The vehicle is equipped with a safety switch which is designed to intervene in the event of a collision, cutting off the fuel supply and consequently causing the engine to stop. It also prevents the fuel spreading if the fuel lines are damaged during the accident. The intervention of the safety switch is indicated by the  warning light appearing on the instrument panel. The switch is positioned inside the left-hand service compartment, in the luggage compartment. To gain access to the switch, open the compartment hatch by pulling the handgrip **A**.



**After impact, if you smell fuel or note any leakage from the fuel supply system, do not reactivate the switch in order to prevent any fire risks. Contact your local Authorized Maserati Dealer immediately.**

### Resetting the switch

Rotate the ignition key to the **STOP** position.

Check that there is no leakage from the fuel system.

If no leaks are found, reset the inertia switch which stops the fuel pump operation, by pressing the button **B** on the switch.

Rotate the ignition key to the **MAR** position, wait for a few seconds and then move it to the **ACC.** position.

Check that the  warning light on the instrument panel is switched off. Check once again that there are no fuel leaks.

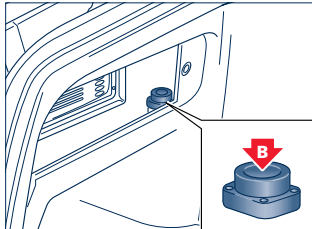
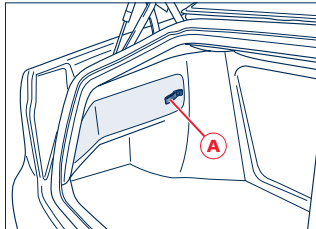

42

Fuel cut-off inertia switch

## Instruments and controls

Dashboard (version with "Cambiocorsa" gearbox)	44
Dashboard (version with manual gearbox)	46
Instrument panel	48
Indicators and warning lights	50
Instruments and indicators	53
Trip odometer reset button	57
Instrument panel dimmer switch	57
Controls and interior equipment	58





### Dashboard (version with "Cambiocorsa" gearbox)

3

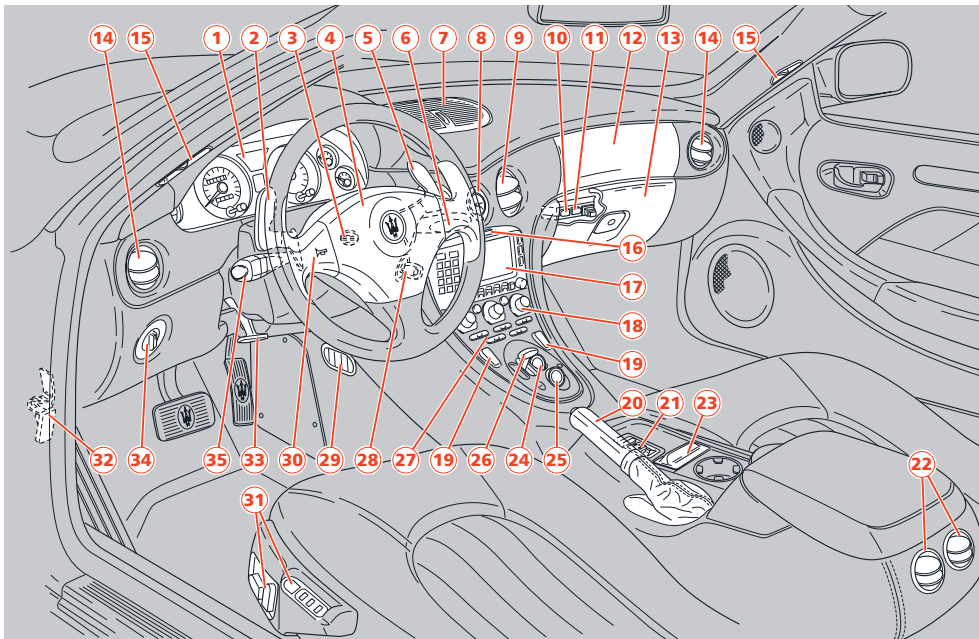

44

Dashboard (version with "Cambiocorsa" gearbox)

- |  |  |   |
|--|--|---|
| <ul style="list-style-type: none"> <li>1) Instrument panel</li> <li>2) Lower gear activation lever DOWN</li> <li>3) Interior temperature sensor</li> <li>4) Driver's airbag</li> <li>5) Upper gear activation lever UP</li> <li>6) Windshield/headlight wiper/washer control lever (optional)</li> <li>7) Upper ventilation and heating outlet</li> <li>8) Clock</li> <li>9) Central air-conditioning and heating vents</li> <li>10) Fuel tank flap control button (located in the glove compartment)</li> <li>11) Luggage compartment lid control button (in the glove compartment)</li> <li>12) Passenger's airbag</li> <li>13) Glove compartment</li> <li>14) Air conditioning and heating system vents</li> <li>15) Side window vents</li> </ul> | <ul style="list-style-type: none"> <li>16) Emergency light switch</li> <li>17) Info Center display and controls</li> <li>18) Ventilation and heating controls</li> <li>19) Electric window controls</li> <li>20) Handbrake lever</li> <li>21) External rear-view mirror controls</li> <li>22) Rear air-conditioning and heating vents</li> <li>23) Ashtray and cigarette lighter</li> <li>24) Pushbutton for "low grip" of the "Cambiocorsa" gearbox</li> <li>25) Push button for "Cambiocorsa" gearbox "automatic mode"</li> <li>26) "Cambiocorsa" gearbox reverse and 1st gear control lever</li> <li>27) Switch unit</li> <li>28) Starter/steering wheel lock switch</li> <li>29) Lower air-conditioning/heating vents</li> <li>30) Horn control</li> <li>31) Seat adjustment controls</li> </ul> | <ul style="list-style-type: none"> <li>32) Hood opening lever</li> <li>33) Steering wheel height and depth adjuster lever</li> <li>34) External lights control</li> <li>35) Cruise Control control lever, direction indicators and low/high beam switch.</li> </ul> |
|--|--|---|





### Dashboard (version with manual gearbox)

3

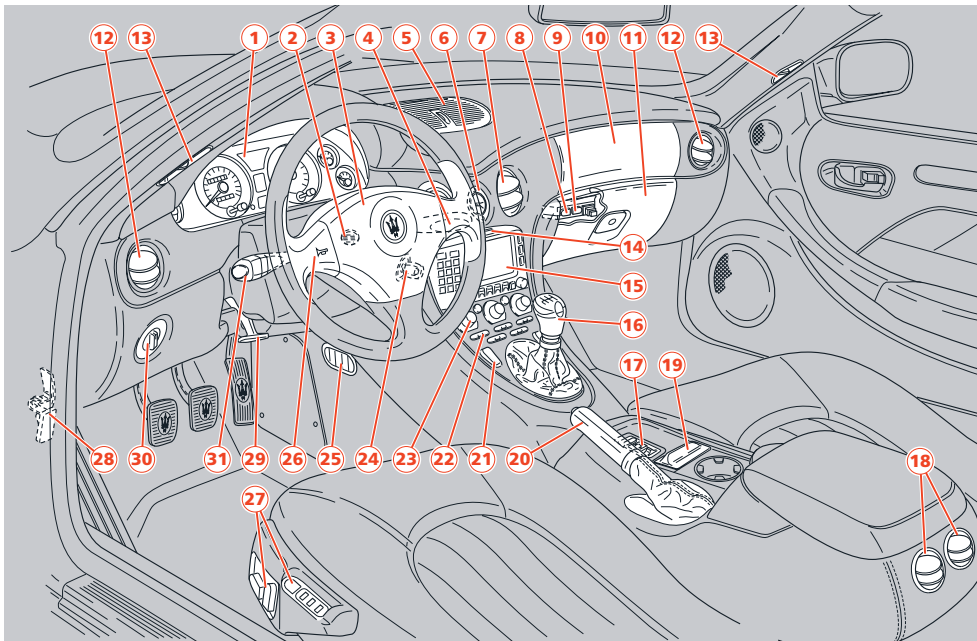

46

Dashboard (version with manual gearbox)

- |   |  |  |
|---|--|--|
| <ul style="list-style-type: none"> <li>1) Instrument panel</li> <li>2) Interior temperature sensor</li> <li>3) Driver's airbag</li> <li>4) Windshield/headlight wiper/washer control lever (optional)</li> <li>5) Upper ventilation and heating outlet</li> <li>6) Clock</li> <li>7) Central air-conditioning and heating vents</li> <li>8) Fuel tank flap control button (located in the glove compartment)</li> <li>9) Luggage compartment lid control button (in the glove compartment)</li> <li>10) Passenger's airbag</li> </ul> | <ul style="list-style-type: none"> <li>11) Glove compartment</li> <li>12) Air conditioning and heating system vents</li> <li>13) Side window vents</li> <li>14) Emergency light switch</li> <li>15) Info Center display and controls</li> <li>16) Gearshift lever</li> <li>17) External rear-view mirror controls</li> <li>18) Rear air-conditioning and heating vents</li> <li>19) Ashtray and cigarette lighter</li> <li>20) Handbrake lever</li> <li>21) Electric window controls</li> <li>22) Switch unit</li> </ul> | <ul style="list-style-type: none"> <li>23) Ventilation and heating controls</li> <li>24) Starter/steering wheel lock switch</li> <li>25) Lower air-conditioning/heating vents</li> <li>26) Horn control</li> <li>27) Seat adjustment controls</li> <li>28) Hood opening lever</li> <li>29) Steering wheel height and depth adjuster lever</li> <li>30) External lights control</li> <li>31) Cruise Control control lever, direction indicators and low/high beam switch</li> </ul> |
|---|--|--|





## Instrument panel

3

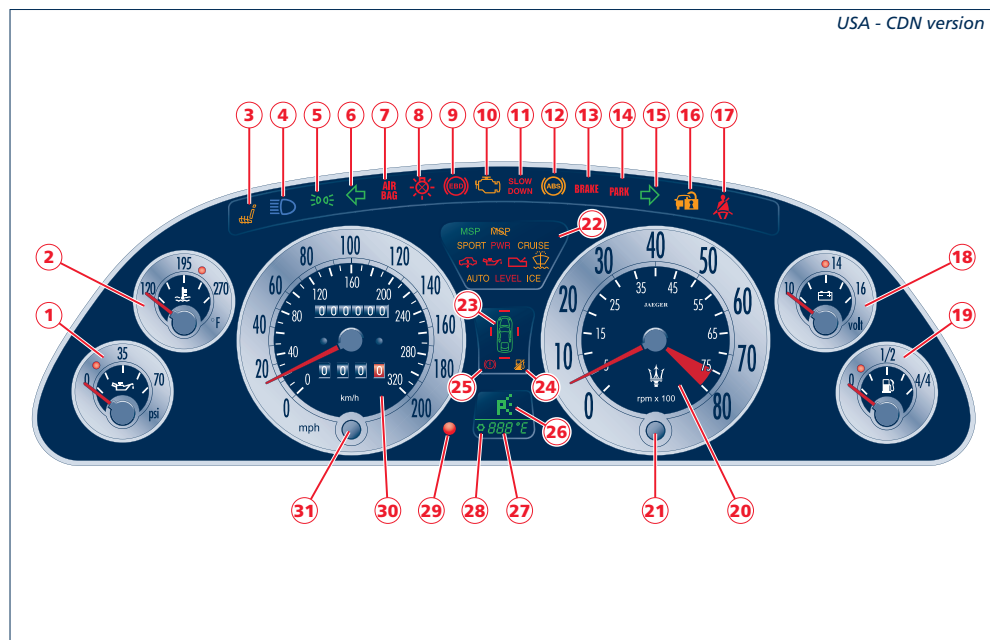

48

Instrument panel

- |  |  |   |
|--|--|---|
| <ul style="list-style-type: none"> <li>1) Oil pressure gauge and low pressure warning light</li> <li>2) Coolant thermometer and high temperature warning light</li> <li>3) Front seat heating warning light</li> <li>4) High beams warning light</li> <li>5) Parking lights/low beams warning light</li> <li>6) Left-hand direction indicator warning light</li> <li>7) Air bag/pretensioners failure warning light</li> <li>8) Light failure warning light</li> <li>9) EBD system failure warning light</li> <li>10) Warning light for OBDII engine control system failure</li> <li>11) Catalytic converter high temperature warning light</li> <li>12) ABS system failure warning light</li> </ul> | <ul style="list-style-type: none"> <li>13) Front brake pad worn/low brake fluid warning light</li> <li>14) Handbrake on warning light</li> <li>15) Right-hand direction indicator warning light</li> <li>16) Maserati CODE system warning light</li> <li>17) Driver's seat belt warning light</li> <li>18) Voltmeter and generator warning light</li> <li>19) Fuel level gauge and low fuel indicator</li> <li>20) Tachometer</li> <li>21) Instrument panel dimmer switch</li> <li>22) Multi-function display</li> <li>23) Doors, engine/luggage compartment open display</li> <li>24) Inertia switch activated warning light</li> </ul> | <ul style="list-style-type: none"> <li>25) Front brake pad worn/low brake fluid warning light</li> <li>26) Indicator for "Cambiocorsa" gear engaged / parking lights on</li> <li>27) External temperature gauge</li> <li>28) External temperature LED: it switches on when the temperature is equal to or lower than 36 °F (+ 2 °C) (icy road surface hazard)</li> <li>29) Electronic alarm device LED</li> <li>30) Speedometer with trip and total distance milometer</li> <li>31) Trip odometer reset button</li> </ul> |
|--|--|---|





## Indicators and warning lights



### Seat heating (optional)

Indicates that the heating device of one or both front seats is turned on.



### High beams

When the high beams are turned on or flashing.



### Parking lights/low beams

It switches on when the dipped lights, low beams or parking lights are turned on.



### Directional indicators

They switch on when the direction lights or the hazard warning lights are turned on.



### Airbag/pre-tensioner failure

When the pre-tensioner and/or airbag system is defective.



Turning the key to MAR, the light comes on but it should go out after a few seconds with the engine running.



If the light stays on or if it does not come on or if it comes on during running, stop immediately and consult the your Authorized Maserati Dealer.



### Light failure warning light

It switches on in the case of system failure or burning-out of the bulbs for the parking, license plate, stop or rear fog lights.



### Electronic brakeforce distribution (EBD) failure warning light

It switches on when the EBD system is defective.

In this case abrupt braking can cause early locking of the rear wheels and possible side skid of the car. Drive with the utmost care and consult your Authorized Maserati Dealer immediately.



### Engine control system failure OBDII

Under normal conditions, the warning light should switch on when the ignition key is turned to the **MAR** position and switch off as soon as the engine is started. This will show that the warning light is working properly. If the warning light remains on or switches on while driving, it indicates that there is a failure in the fuel supply/ignition and emission control systems. The failure could cause high exhaust emissions, loss of performance, poor driving conditions and high fuel consumption levels. Under these conditions you can proceed slowly without demanding engine performance or high speed. Prolonged use of the car when the warning light is on can cause damage. For this reason, you should contact your **Authorized Maserati Dealer** as soon as possible. The warning light will go out if the problem disappears. The error will be stored by the system in any case.

**WARNING:** When you turn the ignition key to the **MAR** position and the  does not light up or switches on when driving the car, contact your **Authorized Maserati Dealer** as soon as possible.



### Catalytic converter high temperature warning light

Turning the key to **MAR** the warning light comes on for self-diagnosis, but should go out after starting the engine.

This warning light starts flashing or comes on with a fixed light when engine malfunction results in high exhaust system temperature.



**WARNING LIGHT FLASHING: catalyst temperature is too high. Reduce speed immediately until the warning light goes out and then drive carefully at moderate speed. Contact your Authorized Maserati Dealer as soon as possible for service.**



**IF THE WARNING LIGHT CONTINUES FLASHING OR STAYS ON AFTER HAVING REDUCED THE SPEED: dangerous temperature in the catalytic converters, catalysts can be damaged. Stop the car immediately and have it towed to the nearest Authorized Maserati Dealer for service.**



**Maserati declines all responsibility any damage caused from non compliance with the above mentioned warnings.**



### Defective wheel anti-lock system (ABS)

Switches on when a problem is detected in the ABS system is defective. The normal brake system remains operational, but it is advisable to contact your **Authorized Maserati Dealer** as soon as possible.



**Front brake pads worn/  
brake fluid low**

Switches on when the front brake pads reach the wear limit or the brake fluid level drops below the minimum level. The operation of the warning light can be checked by pressing the button on the brake fluid reservoir cover located in the engine compartment.

When replacing the front brake pads, also check the rear brake pads for wear.



**If the warning light comes on when the car is travelling immediately check brake fluid level. If fluid level is below the minimum limit there could be a leakage. Contact your Authorized Maserati Dealer before restarting the car.**

**Handbrake on**

The warning light flashes when the handbrake is operated.

**Maserati CODE**

When the ignition key is turned to the **MAR** position, it may switch on under three possible conditions:

- One flash - key code recognized. The engine can be started.
- Fixed light - key code not recognised. To start the engine, follow the emergency starting procedure as specified in the chapter "emergency situations", after having attempted to start it with other keys.
- Flashing light - vehicle not protected by the Maserati CODE. The engine can, however, be started but, contact your **Authorized Maserati Dealer** as soon as possible because the car is not protected against attempts at theft.

**Seat belts**

Switches on when the driver's seat belt is not fastened or fastened incorrectly. A buzzer is also activated for 8 seconds when the light is on.

**Fuel shut-off inertia  
switch on**

Switches on when the inertia switch has been activated following a collision, thereby shutting off the fuel supply.



**After impact, if you smell fuel or leakage is noted from the fuel system do not re-activate the switch in order to prevent the risk of fire. Contact your local Authorized Maserati Dealer immediately.**

## Instruments and indicators

### 1 – Oil pressure gauge

It indicates the engine oil pressure. In normal operation, the needle must be at the center (35 to 70 psi) (2.5 to 5 bar). If it moves towards 0 and at the same time the warning light switches on, stop the car and carry out the necessary checks. The warning light also switches on when the ignition key is turned to the **MAR** position, but it should switch off as soon as the engine starts. A delay in the light going out is permitted only when the engine is idling. If the engine has been required to work at maximum rate, the warning light may flash with the engine idling but it should go out when accelerating lightly.

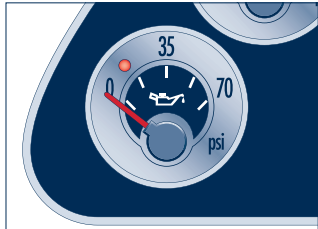

### 2 – Coolant temperature gauge

It indicates the temperature of the coolant. If the needle indicates high temperature and at the same time the warning light switches on, stop the car immediately and have the cooling system checked by your **Authorized Maserati Dealer**.

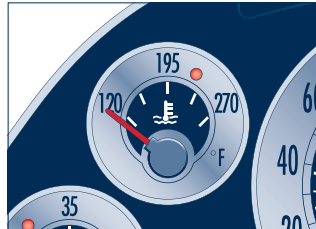

### 20 – Tachometer

It indicates the engine's r.p.m. Correct driving allows the driver to utilize the engine performance fully, without the need for over-revving.



Instruments and indicators





### 18 – Voltmeter

It indicates the battery voltage and the consequent normal operation of the charging system. With the battery in good condition, the engine off and the starter key in **MAR** position, it is located between 10V and 13V.

With the engine running the indicator moves to values over 13V. The low recharge warning light inside the voltmeter indicates possible problems in the recharging system.

When the starter key is turned to the **MAR** position, the warning light switches on, but it should switch off as soon as the engine starts. Any delay in its switching off with the engine idling is not indicative of malfunctioning.

### 19 – Fuel level gauge

The warning light inside the instrument switches on to indicate that there are about 5 US gallons (18 liters) fuel left in the tank.



## 22 – Multi-function display

<b>MSP</b>	Switches on when the MSP system is activated.
<b>MSR</b>	Indicates deactivation or failure of the MSP system.
<b>SPORT</b>	Indicates electronic suspensions "sport" setting.
<b>PWR</b>	Indicates that the SPORT mode is set for the "Cambiocorsa" gearbox.
<b>CRUISE</b>	Indicates that the Cruise Control is activated.



Indicates a failure in the electronic suspensions system.



Engine oil pressure low.



Indicates a failure in the "Cambiocorsa" gearbox.



Indicates windshield/headlight washer fluid low.

**AUTO**

Indicates that the "automatic transmission" mode is set for the "Cambiocorsa" gearbox.

**LEVEL**

Indicates low "Cambiocorsa" gearbox oil level.

**ICE**

Indicates that the "low grip" mode is set for the "Cambiocorsa" gearbox.

## 23 – Doors and engine/luggage compartment open display

Indicates that doors and hood/trunk are open or not properly closed.



Instruments and indicators





### 26 – Indicator for "Cambiocorsa" gear engaged / parking lights on

When the ignition key is turned to the **MAR** position, it indicates that the "Cambiocorsa" gear is engaged:

- N (neutral)
- R (reverse)
- 1 (1<sup>st</sup> gear)
- 2 (2<sup>nd</sup> gear)
- 3 (3<sup>rd</sup> gear)
- 4 (4<sup>th</sup> gear)
- 5 (5<sup>th</sup> gear)
- 6 (6<sup>th</sup> gear)

When the key is removed, it indicates, through the warning light , that the parking lights are on.

### 27 – External temperature gauge

Indicates the external temperature in °C or °F, according to the market.

**WARNING:** When the letter "E" is displayed for several seconds (when starting the engine and before the outside ambient temperature appears) it indicates a malfunction in the heating/air-conditioning system. Contact your **Authorized Maserati Dealer** as soon as possible for service.

### 28 – Outside temperature LED

Switches on when the outside temperature is equal to or lower than 36 °F (+ 2 °C) to indicate the risk of icy road surfaces.

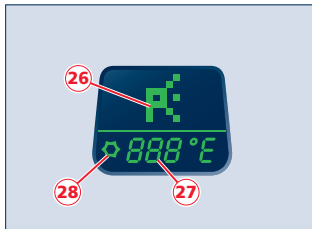



### Trip odometer reset button

Press button **A** to set the trip odometer to zero.

### Instrument panel dimmer switch

Turn button **B**, with the external lights on, to adjust the instrument panel lighting.

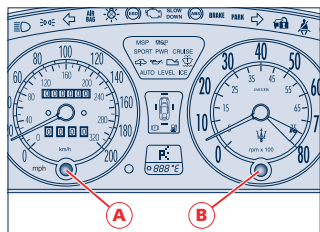

*Trip Odometer reset button / Instrument panel dimmer switch*



## Controls and interior equipment

### Hazard warning lights

Press button **A** to turn on the hazard warning lights. Their operation does not depend upon the position of the ignition key. Press the button again to turn them off. When these lights are on, the directional indicators, the related warning lights on the instrument panel and the button are flashing.

**WARNING:** When the hazard warning lights are activated, the directional indicators control is disabled.

### Heated side window and side-view mirror defroster

Activation of the heated side window and of the side rear view mirror defroster is only possible when the ignition key is in the **MAR** position and by pressing button **D**. Although activation of the heated side window is timed, it is advisable to turn it off as soon as the window is cleared of mist or frost to avoid overloading the battery. When the heated side window is activated, the LED on the button lights up.

**WARNING:** To prevent the battery from going flat, it is advisable to activate the heated side window only when the engine is running.

### Opening the luggage compartment

Press pushbutton **E** (located inside the glove compartment) to open the trunk lid.

Operation is possible only with the ignition key removed or in the **STOP** and **ACC** positions.

Vehicles are also equipped with a lever inside the luggage compartment, which permits opening from the inside.

3

58

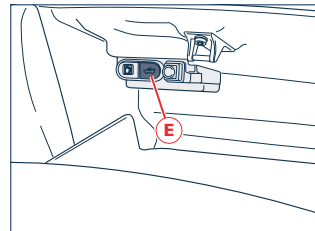
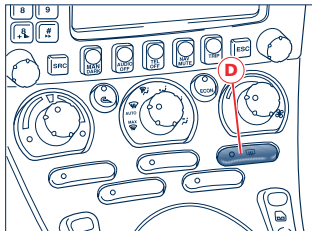

Controls and interior equipment



### Opening the fuel tank flap

Press the **F** pushbutton (inside the glove compartment) to open the fuel tank flap on the right-hand rear side of the car.  
Operation is possible only with the ignition key removed or in the **STOP** position.

### MSP system

The **MSP** system is automatically activated when starting the engine. It is possible to disconnect or reconnect the system during running by pressing button **H**. To prevent inadvertent deactivation, the button is to be pressed for about 2 seconds for deactivating the MSP system. When the MSP system is on, the button led is off, when the system is on the **MSP** warning light on the multifunction display lights up. When the system is off, the LEDs on the pushbutton and the letters **MSP** on the multifunction display light up.

### SPORT setting

On vehicles equipped with electronically-controlled suspensions, pressing button **L** will select the **SPORT** mode, which sets the suspensions, traction control and Cambicorsa gearbox (if available) to a racing-type driving style. Please note that selecting the **SPORT** mode strongly decreases driving comfort, especially in city traffic and on uneven roadbeds.

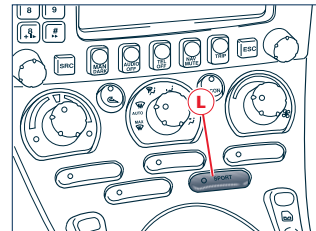
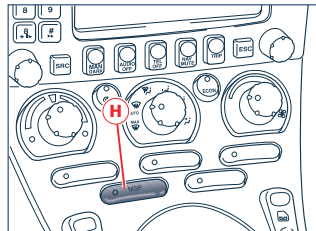
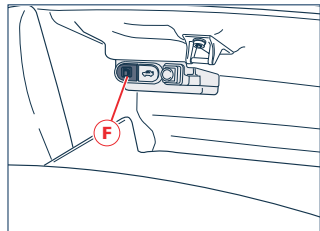

Controls and interior equipment



On vehicles which are not equipped with electronically-controlled suspensions, pressing button **M** will select the **POWER** mode, which sets the traction control and Cambiocorsa gearbox (if available) to a racing-type driving style."

### Clock

Press pushbutton **N** to set the clock: slight pressure = slow adjustment prolonged pressure = fast adjustment. The clock lights up when the external lights are turned on.

### Front overhead lights

The overhead lights include one central light and one reading light. The central light switches on automatically when one of the doors is opened and switches off a set period of time after they are closed. It can also be switched on manually by pressing button **P**. The reading light is controlled by button **Q**.

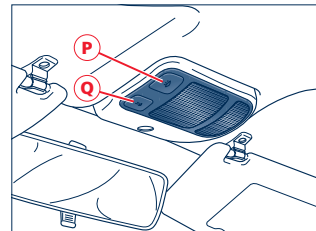
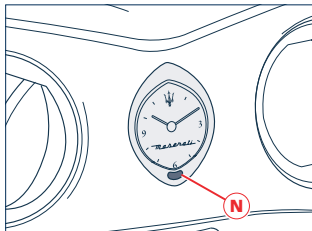
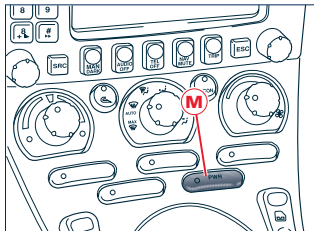



### Rear overhead lights

The rear overhead lights **R**, which switch on automatically when one of the doors is opened and off again after a set time period, are activated manually by pressing the transparent panel at point **S**.

### Sun visors

These can be positioned to the front or to the side. To place the visor sideways, lower it and unhook it from the retainer **T**.

The vanity mirror is accessed by lowering the passenger side visor. Its built-in light switches on automatically (with the ignition key on **MAR**) when the protective cover is opened. Before raising the visor, close the mirror cover.

### Ashtray and cigarette lighter

They are found on the central console under a cover. Press the rear part to open the cover.

Press button **U** down to turn on the cigarette lighter, which automatically returns to its initial position and is ready for use after 20 seconds.

Remove the tray in order to clean the ashtray.

**WARNING:** Always check to ensure that the cigarette lighter has been switched off.

 **The cigarette lighter reaches high temperatures. Handle it carefully and do not allow children to use it because of risk of fire and burns!**

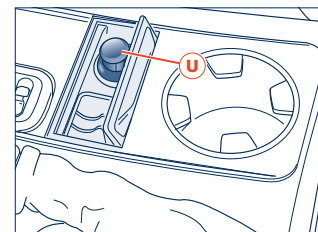
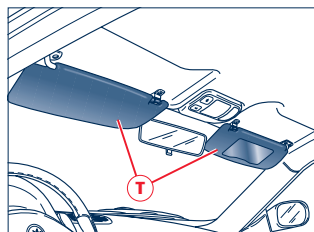
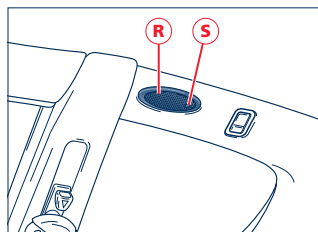

Controls and interior equipment



### Glove compartment

It is positioned in the lower part of the dashboard on the passenger's side, and the opening pushbutton V is equipped with a lock. The compartment is lit by a courtesy light when it is opened.

The glove and luggage compartment locks cannot be operated using the "garage" key. This key therefore, can be used when leaving the vehicle with a garage or parking facility, as it allows the staff to move the car but not to open the glove compartment (if it is closed beforehand with the main key) or the luggage compartment (see on page 69).



**To ensure passenger safety, the glove compartment must always remain closed when the car is running.**

### Center storage compartment

It is found in the rear side of the central console. For access, lift the lid which is pressed shut.

3

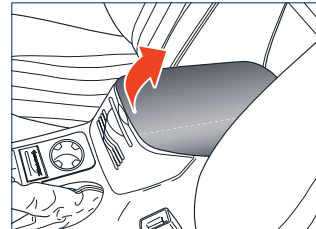
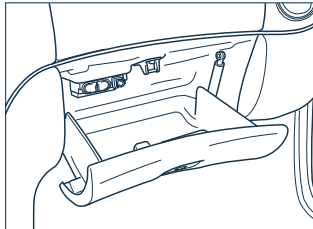
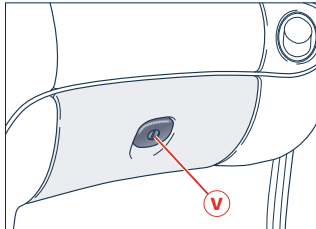

62

Controls and interior equipment

### Glass compartment

This is positioned on the tunnel, near the handbrake lever, and it can contain either a glass or a can.

### Seat pockets

The front seats come equipped with a map pocket on the back.

**WARNING:** Do not store heavy or pointed objects in the seat pockets.

### Coat-hooks

These are found in the rear of the passenger compartment. To pull out a hook press button Z. To reposition it back, push it upwards in its seating.



**When the hooks are not in use, turn them to the closed position.**

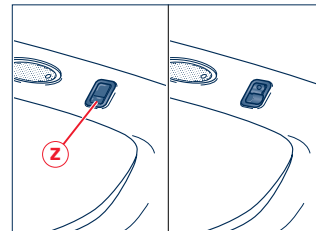
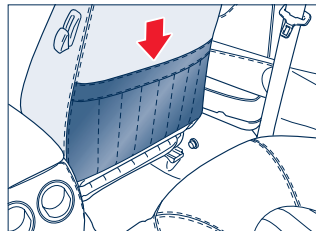
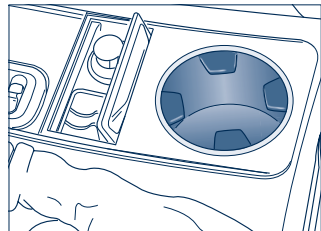

Controls and interior equipment





## Before you drive

Doors	66
Engine compartment hood	68
Luggage compartment	69
Fuel tank flap	70
Keys	71
Ignition switch	74
Electronic alarm device	75
Front seats	80
Rear seats	84
Side-view mirrors	85
Steering wheel	87
External lights and directional indicators	88
Windshield wipers and headlight washers (optional)	90
Maserati Info Center	92
Sound system	100
Air conditioning and heating system	102
Specific luggage set (optional)	109





## Doors

### Opening doors from the outside

Switch off the alarm device and the centralized door locking by the electronically operated control (see paragraph "Electronic alarm device" on page 75).

With the central lock released, lift the handle to open the door. With alarm device off it is possible to open the door by inserting and turning the key in the lock of one of the doors.

### From the inside

The central door lock is switched on or off from the inside of the car using the safety button **A** on any one of the doors.

The central door locking is automatically released by pulling the internal handle of one of the doors.

**WARNING:** If one of the doors is not closed properly or there is a problem in the system, the central door lock will not switch on and after some attempts, the device is disabled for several minutes. During that time, the doors can still be locked or unlocked manually without the activation of the electrical system. After this period the unit is once again ready to receive instructions. If the cause of the malfunction has been eliminated, the device will resume normal operation. If not, the disabling cycle will be repeated.

### Door open warning lights

These warning lights, on the instrument panel, come on when the doors, engine and luggage compartment lids are not properly closed.

### Power windows

Activation is possible only with the ignition key in the **MAR** position.

The controls are found on the central console, in front of the gearshift lever.

**B** - Open/close front left-hand window

**C** - Open/close front right-hand window.

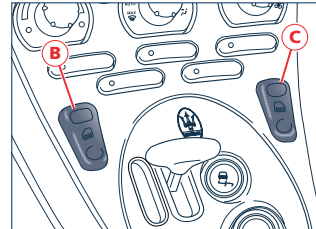
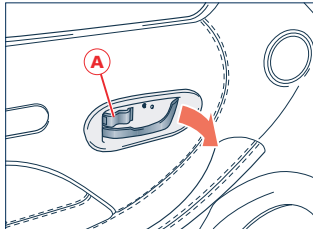
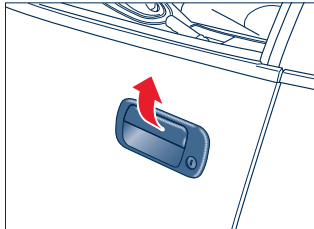



Pressing the window button on the driver side **B** with the key in the **MAR** position operates the window in automatic mode: the window is closed when it reaches the limit stop (or by pressing the button again).

**WARNING:** If the power window is operated with the door open, the window stops before reaching the upper threshold to prevent interference with the strip when closing the door.

 **When the door is opened, the window is slightly lowered and then closes automatically after the door is closed: take the utmost care to avoid passengers (especially children) being near the windows when opening/closing the doors.**

 **Improper use of electric window controls can be dangerous. Check that passengers are away from the side windows before closing them. Always remove the ignition key when you get out of the car in order to avoid accidental activation of the power windows - they can be hazardous for passengers remaining in the car.**

 **Never leave children unattended inside the vehicle: If one or both doors are open or not closed properly, both power windows work even if the ignition key is in the STOP position or if it has been removed. The possibility of the window controls being operated can be very dangerous.**

 **Leaving children in a parked car with the windows shut is dangerous. The temperature inside the car can reach very high levels, causing fainting and serious injury.**

**WARNING:** Before disconnecting the battery, lower the side windows by at least 1.5-2 in (4-5 centimeters), in order to avoid damaging the strips when opening and closing the doors. When the battery is connected and loaded, this operation is carried out automatically upon opening and closing the door. The windows must remain lowered until the battery is connected once again. If the battery runs flat when the windows are fully raised, open the door only if necessary and taking utmost care. Do not close the door as long as the window cannot be lowered.

#### Door open indicator

Each door is fitted with a reflector **D** fitted to the door panel.

#### Buzzer

An intermittent buzzer is activated when, with the driver's door open, the ignition key is turned from position "0" to position "II".

#### Door courtesy light

Each door is equipped with a courtesy light **E**, fitted on the lower part of the door panel to light up the access/exit area of the car.

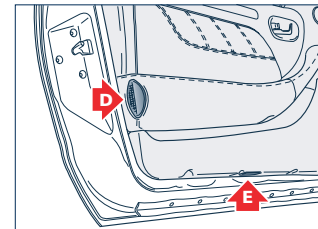

Doors





## Engine compartment hood

To open the engine compartment hood: pull lever **A** located on the lower left hand side of the dashboard.

**WARNING:** If necessary, the engine compartment hood can be released by pulling the eyelet on the emergency cable found near the lever.

Release the safety device by lifting button **B** located in the middle of the grille.

Lifting the engine compartment lid: The procedure is facilitated by the side gas struts.

The engine compartment lid positions itself at the maximum opening position and does not require support stays.

To close the engine compartment lid: lower it to about 8 in (20 cm) from the engine compartment and let it drop; it closes automatically.

4



**Always check that the hood is properly shut so that it cannot open while the car is moving.**

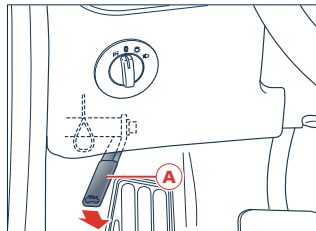

Engine compartment hood

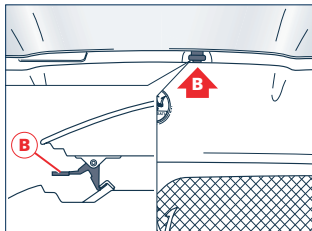

68

## Luggage compartment

The luggage compartment trunk can be opened from the inside or outside of the car. To open it from the inside use button **A**, which is found in the glove compartment. Operation is possible only with the ignition key removed or in the **STOP** or **ACC** position. To open the trunk from the outside, use the ignition key.

Raising the lid is facilitated by the action of the gas struts.

Vehicles are also equipped with a lever inside the luggage compartment, which permits opening from the inside. In addition, the glove and luggage compartment locks cannot be operated using the "garage" key. This

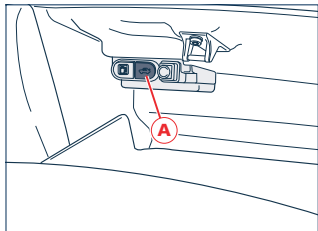

key therefore, can be used when leaving the vehicle with a garage or parking facility, as it allows the staff to move the car but not to open the glove compartment (if it is closed beforehand with the main key) or the luggage compartment.

**WARNING:** The struts are calibrated to help ensure proper operation with the weights specified by the manufacturer. Arbitrary additions of objects (spoilers, trunk racks, etc.) can jeopardize proper operation and safety in the use of the luggage compartment lid.



**When using the trunk, never exceed the maximum loads allowed (see chapter 7, "Capacities and Technical Specifications" on page 173). Also check that the objects contained in the trunk are arranged properly.**

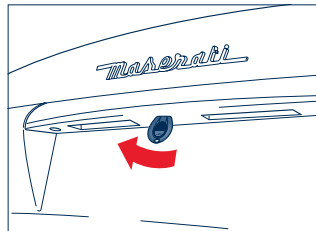

The luggage compartment is illuminated by the ceiling light **B** which switches on automatically when the lid is opened and it switches off after a timed interval.

If the luggage compartment lid is left open, the light switches off after several minutes. To switch it on again, close the lid and then re-open it.

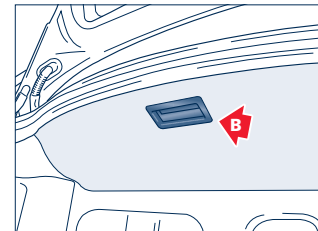

Luggage compartment





## Fuel tank flap

The fuel tank flap is found on the right-hand rear side of the car. To open the flap, press pushbutton **A** which is located inside the glove compartment. Operation is possible only with the ignition key removed or in the **STOP** position.

The cap's hermetic seal may result in a slight pressure increase in the tank. Any hissing noise while the cap is being released is normal.

When refueling, the cap must remain hanging from the flap by means of the respective hook **B**.

The cap is joined to the filler neck with a strap to prevent misplacement while refueling.

The flap must be re-closed manually. Before closing the flap, check that the fuel filler cap is fully tightened.



**Do not bring open flames or lit cigarettes close to the filler because of the risk of fire!**

**Also do not put your face close to the filler so as not to inhale noxious fumes.**

## Fuel tank flap emergency opening

If necessary the flap can be opened by pulling the cable **C** located on the right hand side of the luggage compartment.

4

70

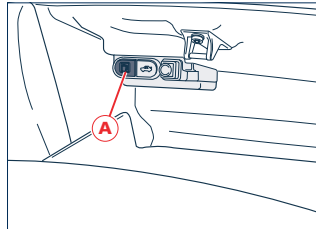

Fuel tank flap

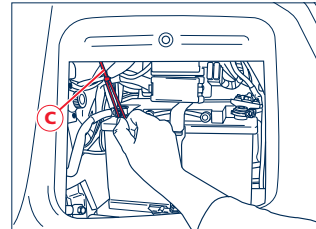
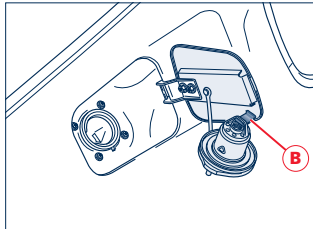

## Keys

### The Maserati CODE system

In order to increase protection against attempts at theft, the car is equipped with an electronic engine immobilizer system (Maserati CODE), which is automatically activated when the starter key is removed.

Each starter key contains an electronic device which transmits a code signal to the Maserati CODE control unit, and engine ignition is enabled only if the key code is recognized by the system. The keys supplied are two of type **A** and one "valet" key, **B**.

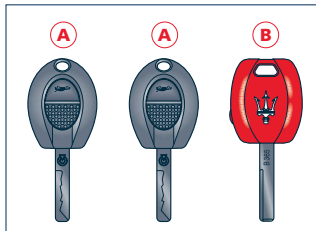

Key **A** can be used for all functions.

Key **B** is used for:



- ignition
- alarm activation/deactivation.



It can be used when the vehicle is left with a garage or parking facility, as it allows the staff to move the car but not to open the glove compartment (if it is closed beforehand with the main key) or the luggage compartment.

### Operation



Each time the ignition key is removed from the **STOP** position the protection system activates the engine immobilizer.

Upon starting the engine, when the key is turned to the **MAR** position:

**1)** If the code is recognized, the **CODE**  on the instrument panel turns off within a second, while the **OBDII**  warning light, once the **ECU** diagnosis has been completed switches off after about four seconds. Under these conditions, the protection system recognizes the key code and deactivates the engine immobilizer. When the key is turned to **AVV**, the engine starts.

**2)** If the warning light **CODE**  remains on and the warning light **OBDII**  switches off and comes on again immediately, after the four second diagnostics for the **ECU** control units, the code has not been recognized. In this case, it is advisable to turn the key back into position **STOP** and then back to **MAR**; if the immobilizer stays on, try with the other keys. If it is still not possible to start the engine, try the emergency start-up procedure (see chapter "Emergency starting" on page 144) and contact your **Authorized Maserati Dealer**.

Driving with the ignition key on **MAR**:

**1)** If the warning light **CODE**  switches on, it means that the system is carrying out a self-diagnosis check. At the first stop you can test the system: turn the engine off by rotating the ignition key to the **STOP** position and then turn the key back into position. **MAR**: the warning light **CODE**  will switch on and off within a second. If the LED stays on, repeat the procedure described previously leaving the key at **STOP** for more that 30 seconds. If the problem persists, please contact your **Authorized Maserati Dealer**.





2) If the warning light **CODE**  is flashing, it means that the vehicle is not protected by the engine immobilizing device. Contact your **Authorized Maserati Dealer** immediately to have all the keys stored in the memory.

**WARNING: Strong impact can damage the electronic components in the key.**



**WARNING: Each key supplied has its own specific code, which must be stored in the memory of the system control unit.**

4

### Duplicating the keys





When ordering additional keys, remember that memorizing (up to maximum of 7 keys) must be carried out on all the keys, including those already in your possession. Contact your **Authorized Maserati Dealer** directly, bringing with you all the keys in your possession, the Maserati CODE system CODE CARD, the electronic alarm device CODE CARD, a personal ID and the identification and registration documents proving ownership of the car. The codes of any keys that are not available when the new storage procedure is carried out will be deleted from the memory to prevent any lost or stolen keys being used to start the car.

### Emergency starting

If the Maserati CODE is unable to deactivate the engine immobilizer, the warning light **CODE**  remains on, whereas the warning light **OBDII**  switches off for four seconds to come on again immediately, and the engine does not start. The engine can only be started with the emergency procedure.

**WARNING: It is recommended to read the whole procedure through carefully before carrying it out.**

If an error is made, turn the key back into position **STOP** And repeat the procedure starting from step 1.

- 1) Read the 5-digit electronic code found on the CODE CARD.
- 2) Turn the key to position **MAR**: at this point, the **CODE**  and **OBDII**  warning lights stay on.
- 3) press the accelerator pedal down and keep it pressed. After about 8 seconds, the warning light **OBDII**  switches off. Release the accelerator pedal and count the number of times the warning light **OBDII**  flashes.

4) Wait until the number of flashes is the same as the first digit on the CODE CARD and then press the accelerator pedal down and keep it pressed until the warning light **OBDII**  switches off, after being lit for about 4 seconds, then release the accelerator.

5) The warning light **OBDII**  will start flashing again. As soon as the displayed number of flashing is equal to the second digit of your CODE CARD, press down the accelerator pedal and keep it pressed.

6) Proceed in the same manner for the remaining digits in the code on the CODE CARD.

7) When the last digit has been entered, keep the accelerator pedal pressed down. The warning light **OBDII**  will switch on for 4 seconds and then switch off; release the accelerator.

8) Rapid flashing of the warning light **OBDII**  (for about 4 seconds) confirms that the procedure has been completed.

9) Start the engine by turning the key from position **MAR.** to position **AVV.**

If the warning light **OBDII**  remains on, turn the key to position **STOP** and repeat the procedure from step 1.

**WARNING:** After an emergency start-up procedure, we advise you to contact your **Authorized Maserati Dealer** since the emergency procedure must be performed after each start.





## Ignition switch

The starter switch can turn in 4 positions:

**STOP** - Engine off, engine immobilizer and steering wheel lock activated, connected devices excluded apart from those that are not key-controlled (e.g. centralized door lock, trunk opening control, etc.). The key is removable.

**ACC** - Position for cigarette lighter. The key is not removable.

**MAR** - ON position. All electrical devices can operate.

**AVV** - Engine start up.

A buzzer is activated if the ignition key is turned to the "MAR" position while the driver's door is open.



**In the event of tampering with the starter switch (e.g., attempted theft), have it checked by your Authorized Maserati Dealer before restarting the car.**



**When you get out of the car, always remove the key to prevent someone from accidentally activating the controls or starting the car.**

**Remember to apply the handbrake and, if the car is on a hill, put it in first gear.**

**If the car is on a downward slope, engage reverse gear.**

**With the "Cambiocorsa" transmission, always shift to the P position.**



**Never leave children unattended in the car.**

4

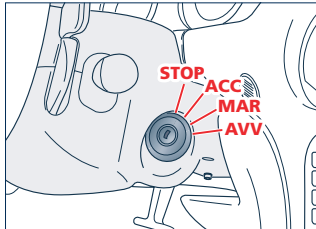

Ignition switch

74

## Electronic alarm device

The electronic alarm device carries out the following functions:

- remote management of the centralized door locking/unlocking
- perimeter surveillance, detecting the opening of doors, engine hood and trunk lid
- motion surveillance, detecting intrusion in the passenger compartment
- car movement surveillance.

**WARNING:** The engine immobilizer function is provided by the Maserati CODE system, which is automatically activated when the ignition key is removed from the starter switch.

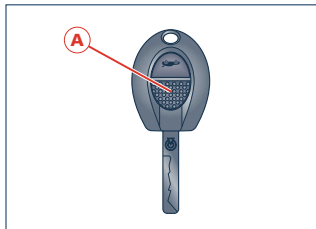

## System activation

To turn on the electronic alarm system, press button **A** on the key:

- the direction indicators flash twice;
- the red LED **B** flashes on the instrument panel;
- the car's centralized door locking system is activated, thereby locking the doors.

**WARNING:** If the button on the key has been pressed out of its range more than 16 times, it must be pressed twice consecutively in order to control the electronic alarm system again.

The alarm system becomes operative after approximately 25 seconds and the alarm is activated when:

- a door is opened
- the luggage compartment trunk is opened
- the engine engine compartment hood is opened
- someone attempts to enter the car from a window
- the power supply is off
- the siren is disconnected
- the car is moved.

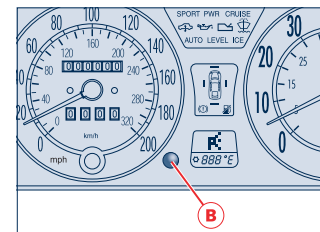

Electronic alarm device





Should directional indicators be flashing 8 times when you activate the alarm system, this means that one of the doors or the hood/trunk is not closed and therefore is not protected by the perimetral surveillance. Check for correct closing of doors, hood/trunk and close the open one without deactivating the alarm system: the directional indicators flashing once indicate that now the door, hood/trunk are closed properly and are protected by the perimetral surveillance.

4

**WARNING:** If the directional indicators flash 8 times when the alarm system is activated with doors, hood and trunk properly closed, it means that the self-diagnosis function has detected a malfunction in the system and that you should contact your **Authorized Maserati Dealer** to have the system checked.

#### Deactivation

To switch the electronic car alarm off, press the key button **A**:

- the directional indicators flash once;
- the red led **B** on the instrument panel switches off;
- the centralized door lock system is activated and the doors are unlocked.

The alarm system is off and it is therefore possible to get into the car and to start the engine.

#### Exclusion of passenger compartment motion sensor (ultrasound system)

If you wish to park the car with the windows lowered or leave a child or pet in the car and activate the alarm system, the internal motion sensor must be deactivated.

To activate the electronic alarm system excluding the passenger compartment motion sensor control, keep the key button pressed for approximately 3 seconds during activation:

- the direction indicators flash once;
- the red LED on the instrument panel remains on for about 25 seconds.

The system is active after about 25 seconds, but movement inside the passenger compartment or intrusions through the open windows will not activate the alarm.

### Alarm memory

Should the red LED **B** on the instrument panel be flashing when you deactivate the alarm system, this means that during your absence the alarm system was activated.

1 switching off ever 6 seconds = passenger compartment volume control alarm

2 switching offs ever 6 seconds = door alarm

4 switching offs ever 6 seconds = hood/trunk alarm

16 switching offs ever 6 seconds = self-powering alarm.

The alarm system memory is reset when you turn the ignition key.

### Market homologation

The electronic alarm device is compliant with the current federal legislation covering radio frequencies. For those markets that require the transmitter and/or receiver marking, the approval number is found on the component.

### Ordering extra radio operated controls

For purchasing new keys with a remote control contact your **Authorized Maserati Dealer** and remember to bring with you:

- all the keys in your possession with related remote control
- the Maserati CODE system CODE CARD
- the electronic alarm device CODE CARD
- a personal ID
- the identification and registration documents proving ownership of the car.

**WARNING:** Radio-operated controls that are not provided for the new code storing procedure will be automatically deactivated in order to prevent any lost or stolen radio-operated controls from being used to deactivate the electronic alarm device.





### Replacing the Key radio control batteries

If pressing one of the two key buttons, **A** or **B**, the related function (activation/deactivation of the electronic alarm, opening of the luggage compartment lid) is not activated, check that the alarm system is working using the other key. If it functions using the other key, the first radio control battery must be replaced.

- To replace the radio control battery:
- separate the two halves of the key using a small screwdriver
  - take the battery **C** off the retaining ring **D**
  - insert a new battery of the same type under the ring, observing the indicated polarity
  - put the two halves of the key back together.

**WARNING:** Do not use sharp tools to separate or join the key casing and take the maximum care to avoid damages.

4

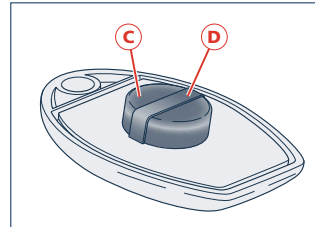
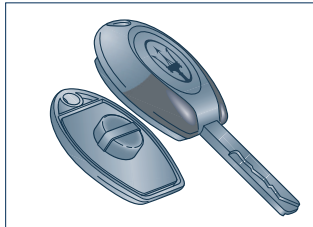
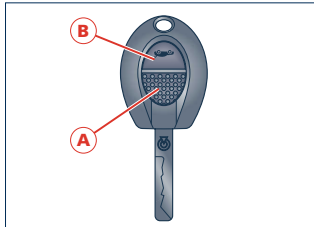

78

Electronic alarm device

### Replacing "valet" key radio control batteries

If pressing the radio operated control button does not cause the electronic alarm activation or deactivation, the battery must be replaced (after checking correct operation of the electronic alarm with another radio operated control).

To replace radio operated control batteries:

- separate the two parts of the key casing using a small screwdriver
- remove the ring with the two batteries
- insert the new batteries in the ring with the (+) sign facing upwards
- re-position the ring with the batteries
- close the key casings.

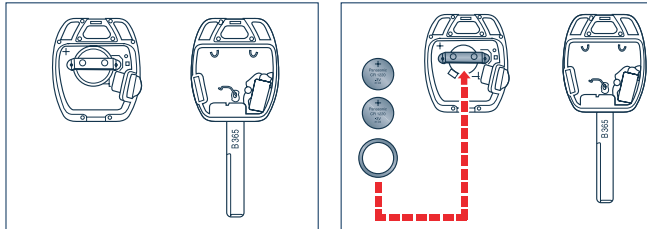



## Front seats

 Only adjust the seat when the car is stationary. You could lose control of the car while driving. Moving the seat could distract you or make you press a pedal unintentionally. Adjust the driver's seat only when the car is stopped.

Seat adjustment is possible only with the ignition key in the **MAR** position. However, with the door closed, seat adjustment operation is possible for about 15 seconds after turning the ignition key to the **STOP** position and then for another 15 seconds after the last operation.

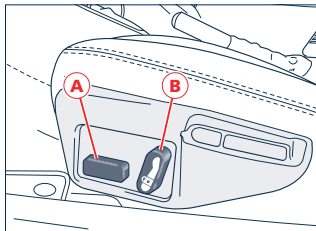

Front seats

### Back/forward adjustment

Push control **A** on the outer side of the seat forward or back.

**WARNING:** On vehicles equipped a fire extinguisher (optional), forward movement of the passenger seat is limited in order to prevent interference with the fire extinguisher.

### Height adjustment

Grip control **A** at the center and push down or up.

### Seat angle adjustment

- Front part of seat: push the front end of control **A** up or down.
- Rear part of seat: push the rear end of control **A** up or down.

### Seat back angle adjustment

Push lever **B** forward or backward to bring the seat backrest to raise or lower the backrest.



Sitting in a reclined position while the vehicle is in motion could be dangerous. The seatback should not be tilted back too far. The 3-point shoulder/lap belt must remain firm against the occupant's body in order to function properly. Therefore, both the driver's and passenger's reclining seatbacks must always be in a fairly upright position while the vehicle is in motion; otherwise the 3-point shoulder/lap belt would not remain firm against the occupant. Serious injury could result!

### Lumbar support adjustment

Push lever **B** up or down to the most comfortable position.

### Seatback tilt

To tilt the seatback on the front seats, lift lever **C** and move the seatback forward. To facilitate access to the rear seats or getting out of the car, the front seats come equipped with the "Easy Entry" device (operational only with the door open), which moves them forward and downward automatically when the seat back is completely tilted and returns them to the driving position when it is straightened.

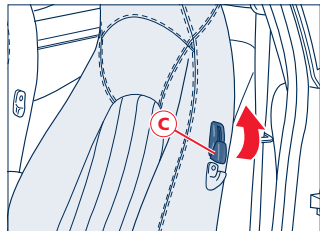

**WARNING:** The system (excluding the seat with position memory) also includes a safety device which stops the seat and then moves it a short distance forward if the seatback knocks against passengers sitting in the back seats. To stop the seat at any point during the automatic forward or reverse movement, use control **A**.



**The front seat must not be occupied when tilting or straightening the seatback. Passengers may only get into and out of the rear seat when the front ones are stationary. Be very careful that rear seat passengers (especially children) do not touch the seat and its guides when it is in motion.**

### Seat heating (optional)

To turn on the seat heating option, press the respective pushbutton **D** for a few seconds. Seat heating is independent: you can heat the right seat or the left one or both. Heating of one or both seats is displayed by the relevant LED on the instrument panel.

**WARNING:** Turn off the seat heating option when it is not needed, in order to avoid unnecessary power consumption.

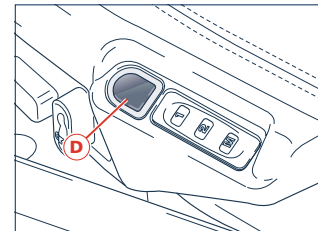

Front seats





### Storing the seat and side rear view mirror position (optional)

The system allows the user to store and recall two different positions of the driver's seat and of the side rear view mirrors.

Storage is only possible with the ignition key in the "MAR" position. Adjust the seat and side rear view mirror positions, then shift the gear to reverse and arrange the mirrors once again so as to find the optimum field of view for executing maneuvers. Afterwards, disengage the reverse gear.

Then, simultaneously press button "M" and button "1" or "2", each one corresponding to a storable position, until the double beep is heard for confirmation.

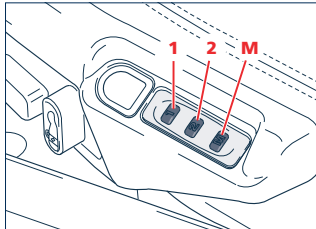

Front seats

Storage of the seat position does not include the lumbar area seat-back adjustment.

When a new seat position is stored, the previous one memorized with the same button is automatically deleted. To recall one of the positions stored, with the door open, push the relevant button "1" or "2" for approximately 3 seconds.

A stored position can also be recalled with the door closed, keeping the relevant button pressed until the seat-locking beep is heard.

**WARNING:** To stop the seat, press one of the following pushbuttons "M", "1" or "2", or one of the adjustment controls.

**WARNING:** Malfunctioning of the seat control unit is indicated by a sequence of 5 tones emitted when the ignition key is turned to the STOP position: see your Authorized Maserati Dealer for service.

### System initialization

When reconnecting the power supply after a power cut-off (e.g. the battery master switch is activated, the fuse burns out or the battery goes flat), check that the seats work correctly: if not, carry out the following procedures on both seats.

With the ignition key in the STOP position and the door closed on the side of the seat concerned, open the door and start the following procedure within 5 seconds.

You must then complete it within 10 seconds:

- 1) forward - STOP
- 2) backward - STOP
- 3) forward - STOP
- 4) backward - STOP
- 5) tilt the seatback completely and wait until the seat performs two complete travels (forward and backward)
- 6) return the seatback to the normal position.

### Headrest

Headrests are integrated in the seats.

### Armrest Center Storage compartment

The front seat armrest is found in the back of the central console. Rise the armrest to access the center storage compartment.

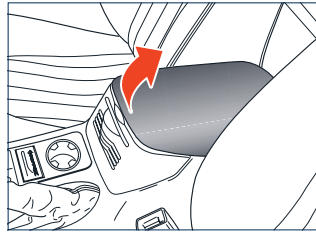
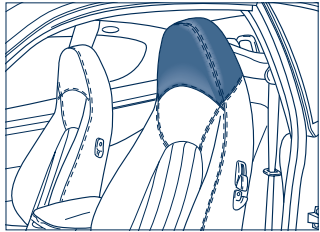



## Rear seats

### Armrest

The rear armrest is movable and can be inserted into the backseat. To lower it, pull handle **A**.

### Headrest

The rear headrests are a fixed part of the seatback.

4

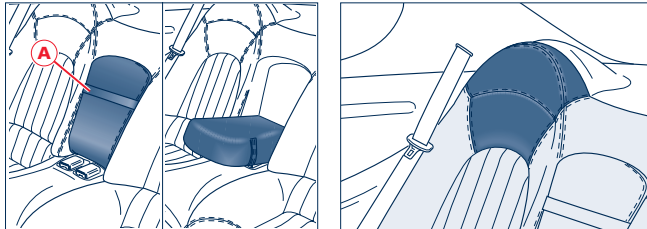

84

Rear seats

## Side-view mirrors

### External side-view mirrors

Can be adjusted electrically (with the ignition key in the **MAR** position) and they are equipped with anti-mist defrosters.

- Mirror selection (right-hand or left-hand): move the selector **A** to the right or left, depending upon the mirror you wish to adjust. Bring the selector back to the center to prevent mirror position being changed involuntarily.
- Mirror positioning: control **B** allows each mirror to be adjusted with four movements (up – down – right – left).

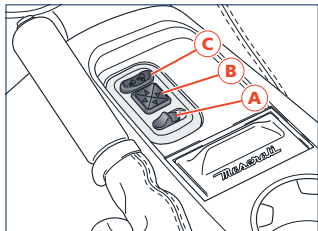

- Mirror retraction: when button **C** is pressed, both mirrors retract to allow parking in restricted spaces. Pressing the button again returns the mirrors to their open position. The mirrors will yield in both directions in the event of a collision.

On versions equipped with memory seats, the position of the side rear view mirrors is automatically stored along with that of the seat, whether they are positioned for normal car driving or for reverse maneuvers.

To store a new side rear view mirror position, turn the ignition key to "**MAR**" and adjust the mirror positions; then shift the gear to reverse and arrange the mirrors once again so as to find the optimum field of view for executing maneuvers. Afterwards, disengage the reverse gear. Lastly, simultaneously press button "**M**" and buttons "**1**" or "**2**", each one corresponding to a storable position, until the double beep is heard for confirmation. The new side rear view mirror position will be stored automatically along with the seat position. It is also possible to modify the side rear view mirror position for normal driving only or for reverse maneuvers.

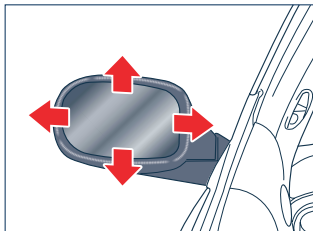

Side-view mirrors





The side rear view mirrors feature different curvatures; the left-hand mirror is flat, while the right-hand one is convex.

 **Pay particular attention as objects viewed in the right-hand mirror are closer than they appear.**

**WARNING:** Do not retract the mirrors manually as this could damage the powering mechanism.

4

 **The mirrors must always be in the open unretracted position when the car is moving.**

### Electrically-shaded interior rear-view mirror

The electrically shaded rearview mirror automatically operates an anti-blinding function by gradually shading as the light shining on the mirror increases.

This function is automatically deactivated in reverse to ensure maximum visibility of obstacles.

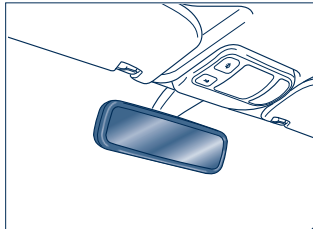
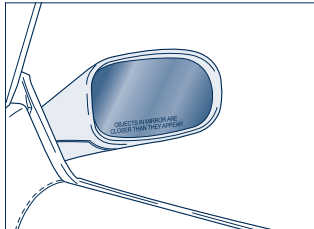

86

Side-view mirrors

## Steering wheel

The steering wheel can be adjusted for height and depth.

- Move lever **A** to position **1**.
- Make the steering wheel height and depth adjustments.
- Move lever **A** back to position **2** to re-lock the steering wheel.



**Do not adjust the steering wheel with the car moving.**



**Under no circumstances remove the steering wheel; this procedure, if necessary, must be carried out by an Authorized Maserati Dealer.**

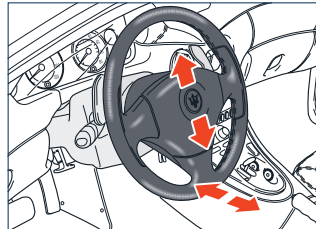
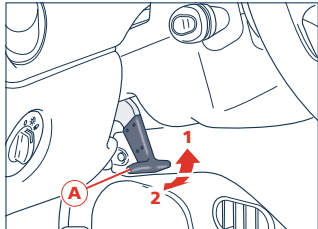





## External lights and directional indicators

The external lights and directional indicators switch on only with the ignition key in the **MAR** position, with the exception of the parking lights, which can be turned on at any time. On **CANADIAN** version vehicles, in accordance with the current regulations, when the ignition key is turned to the "MAR" position the dipped, low beam, license plate and side-marker lights switch on automatically, even during the day, and cannot be switched off ("Day Time Running Lights" function).

4

### Light switch

Switch **A** has 4 settings:

- 0 – Lights off
-  – Dipped, license plate and side-marker lights on
-  – Low beams on
-  – Parking lights

### High beams

To turn on the high beams with the light switch in the  position, push the left lever towards the dashboard. Subsequently pushing the lever towards the steering wheel will switch off the high beams and switch on the low beams.

**WARNING:** For the use of the high beams, observe local driving regulations.

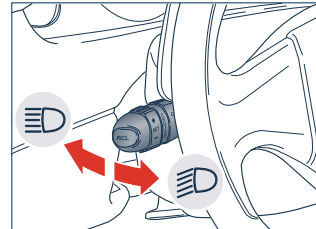
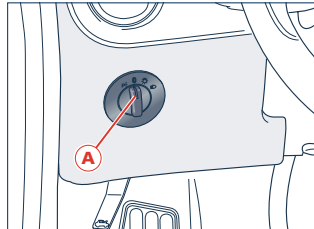

### Flashing the headlights

Headlights can be flashed by pulling the left-hand lever towards the steering wheel.

Headlights can be flashed even with the lights switched off, if the ignition key is in the **MAR** position.

**WARNING:** Flashing takes place with the high beams. Observe current local driving regulations.

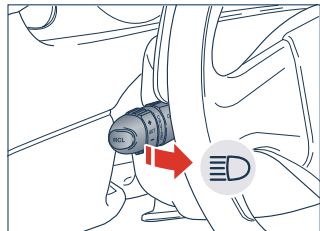

### Parking lights

The parking lights work only with the ignition key in the **STOP** or **ACC** positions, or with the key removed.

They are switched on by turning the light switch to the **P** position.

When the parking lights are on, the warning light on the **P** switches on.

With the parking lights turned on, the dipped lights only on the left-hand side can be turned on by lowering the left-hand lever, whereas only the right-hand dipped lights turn on when you shift it upwards.

### Directions indicators

3-position lever:

**B** - Off

**C** - Lever up: right indicators

**D** - Lever down: left indicators.

**WARNING:** To indicate a temporary lane change, requiring only a slight turn of the steering wheel, it is possible to shift the lever without clicking it into position (non-permanent position).

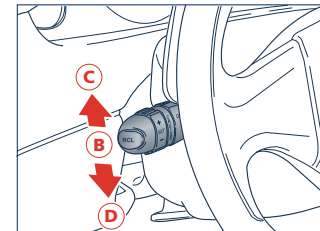

External lights and directional indicators





## Windshield wipers and headlight washers (optional)

The windshield wiper and washer work only with the ignition key in the **MAR** position.

### Windshield wiper

The lever has 5-settings:

- A** - Windshield wiper stopped.
- B** - Adjustable intermittent operation (lever stopped on the first click).
- C** - Slow continuous operation (lever stopped on the second click).
- D** - Fast continuous operation (lever stepped on the third click).
- E** - Fast temporary operation and washer started (non-permanent position).

The windshield wiper and washer are started by shifting the lever in the **E** position. Windshield washer operation is timed, whereas windshield wiper operation is limited to the time in which the lever is manually held in that position. Upon release, the lever automatically returns to the **A** setting and the windshield wiper stops.

### Intermittent operation-frequency

To regulate the frequency of intermittent operation, with the lever on the **B** position, turn locking **F**. Turning the coaxial locking clockwise, intermittent operation varies from fast intermittent wipe to slow intermittent wipe.

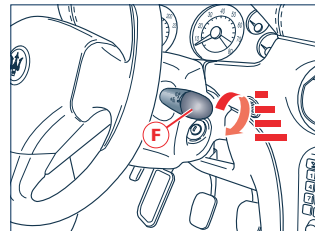
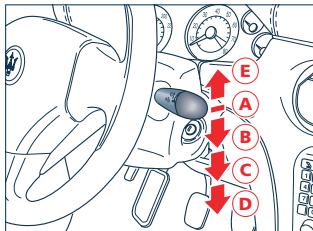

Windshield wipers and headlight washers (optional)



### Windshield washer

Pulling the lever towards the steering wheel (non-permanent position) activates the windshield washer and wiper.

When the windshield washer is activated, the windshield wiper starts automatically. Releasing the lever cuts off the jet of fluid while the blades continue to wipe for a few strokes.

**WARNING:** Do not start the windshield washer during the cold months until the windshield has warmed up. If it has not warmed up, the liquid could freeze on the glass and block the view.

### Headlight washers (optional)

The headlight washers are activated automatically when the windshield washer is started and the external lights are on.

The headlight washer liquid is contained in the same windshield washer tank and depletion is indicated when the respective warning light on the instrument panel lights up.

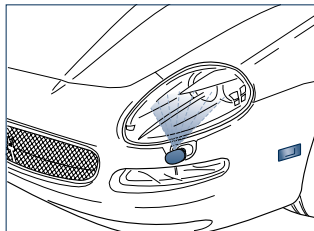
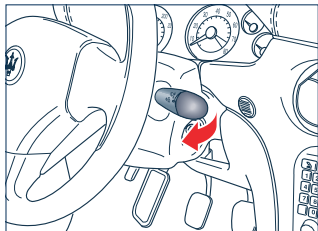

Windshield wipers and headlight washers (optional)



## Maserati Info Center

The car is equipped with the Maserati Info Center infotelematic system that includes the radio set with CD-ROM/ Audio player. Navigation system (optional), on-board computer and ventilation and heating system.



**The navigation system assists the driver with directions to take to reach the set destination through voice messages and graphic information. The suggestions supplied by the navigation system do not relieve the driver from complete responsibility for the maneuvers made through traffic while driving the car or from compliance with driving regulations and other provisions regarding road traffic. The person driving the car is always responsible for safe driving on the road.**

The system controls and main functions are listed below. The car is equipped with a specific supplement describing the Maserati Info Center system fully and listing all of the warnings and precautions for use; it is indispensable for safe use of the system. We advise you to read this enclosure carefully and completely and to keep it within reach at all times (e.g., in the glove compartment).

**WARNING:** Only use the original CD supplied with the car or, other CDs of the same brand, for the Maserati Info Center navigation system.



### Controls

Some controls have multiple functions, depending on the system current operating conditions.

In some cases, the activation of the function selected is controlled by the pressure on the button (short or prolonged press) as listed in the following table.

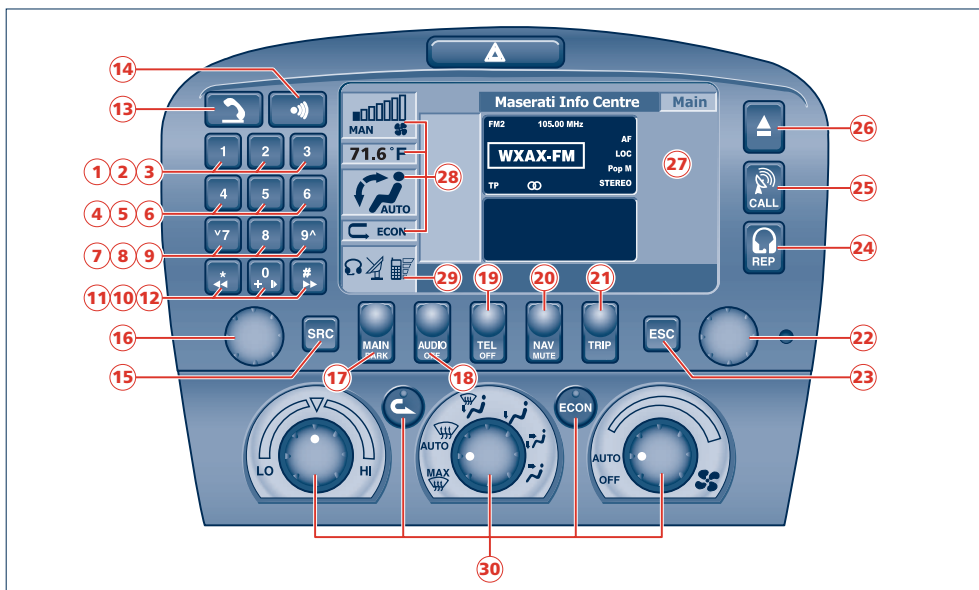



Maserati Info Center



Keys	Pushbutton pressed briefly (less than 1 second)	Pushbutton pressed at length (more than 1 second)
1 - 2 - 3 - 4 - 5 - 6	Saved stations recall.	Save stations nos.1-2-3-4-5-6.
7	Next CD selection on the CD Changer (if installed).	-
8	Inactive button.	-
9	Previous CD selection on the CD Changer (if installed).	-
10	Audio CD Play/Stop.	Audio CD Pause.
11 - *	Radio mode: search for first tunable station with a lower frequency. CD mode: previous track selection.	-
12 - #	Radio mode: search for the first tunable station with a higher frequency. CD mode: next track selection.	-
13 -	Inactive button.	Reject incoming telephone call.
14 -	Inactive button.	-
15 - SRC	Operating mode selection: FM1-FM2-FM3-LW-MW-CD-CDC.	-
16 - ON/ OFF VOL	System on/off (press the knob). Volume control (turn the knob).	-
17 - MAIN/ DARK	Main menu page selection.	Monitor screen blanked (stand-by).
18 - AUDIO/ OFF	Radio menu page selection.	Radio off.
19 - TEL/ OFF	Inactive button.	-
20 - NAV/ MUTE	Navigator function selection.	Switch off/restore navigator voice messages (NAV/MUTE mode).
21 - TRIP	On-board computer menu page selection.	-



Keys	Pushbutton pressed briefly (less than 1 second)	Pushbutton pressed at length (more than 1 second)
22 - SEL	Function selection (turn the knob). Confirm function selected (press the knob). Activation of the pull-down menu (press the knob with MAIN or navigation menu page).	-
23 - ESC	Quit the menu page selected. Return to higher menu level and cancel any functions that have not been confirmed.	-
24 - REP	Inactive button.  REP	-
25 - CALL	Inactive button.  CALL	-
26 - ▲	Ejection of the navigator CD-ROM or audio CD.	-
27	Display infotelematic system functions.	-
28	Display interior temperature and Heating/Air conditioning functions.	-
29	Display GPS signal intensity. Earpiece activated.	-
30	Heating and air conditioning controls.	-



### Slot for navigator CD-ROM/ audio CD

The slot **A** for the navigator CD-ROM and audio CDs is found on the central console.

4

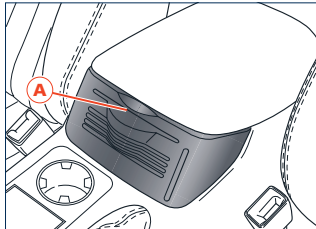

Maserati Info Center

96

### Rapid guide

When using the system, after having activated the main menu page for one of the functions, follow the various options given on the submenu pages that appear by pressing the respective key briefly. Any elements that cannot be selected are always displayed in grey.

For the reference numbers, see the figure in section "Controls" on page 93.

The main functions of the Maserati Info Center are activated by pressing the following keys:

- MAIN MENU PAGE = MAIN key (17)
- RADIO WITH CD PLAYER = AUDIO key (18)
- NAVIGATION = NAV key (20)
- ON BOARD COMPUTER = TRIP (21) key
- SYSTEM SETTINGS: press the right-hand knob (22) when the MAIN page is displayed and select the "Del.Reg.", "Setup" and "Configurat." functions.

### Switching the system on and off

**AUTOMATIC SWITCHING ON:** starting the engine (key on **MAR**).

**MANUAL SWITCHING ON:** press the left-hand knob (16).

**AUTOMATIC SWITCHING OFF:** turning the key to **STOP** (engine stops).

Switching off delayed for 20 minutes if a destination has been entered or if the system was switched on manually with the engine off.

**MANUAL SWITCHING OFF:** press the left-hand knob (16).

### Blanking of the monitor screen

**MONITOR BLANKING:** press the MAIN key (17) at length.

**MONITOR REACTIVATION:** press the MAIN key (17) briefly.

**MONITOR SCREEN BRIGHTNESS**

**ADJUSTMENT:** display the main page (MAIN key (17), press the right-hand knob (22) and select the "Setup" function.

#### **Selection and activation of the menu functions**

**FUNCTION SELECTION:** turn the right-hand knob (22).

**SELECTED FUNCTION CONFIRMATION:** press the right-hand knob (22).

**BACK TO PREVIOUS PAGE AND SAVE NEW SETTINGS:** select and confirm "OK".

**BACK TO PREVIOUS PAGE WITH PREVIOUS SETTINGS:** press the ESC key (23).

#### **Volume adjustment**

**RAISING THE VOLUME:** turn the left-hand knob (16) in a clockwise direction.

**LOWERING THE VOLUME:** turn the left-hand knob (16) in a counter-clockwise direction.

**RADIO OFF:** press the AUDIO key (18) at length.

**RADIO ON:** press the AUDIO key (18) briefly.

**NAVIGATOR VOICE MESSAGE VOLUME ADJUSTMENT:** turn the left-hand knob (16) during the voice message and if necessary, press the REP key (24) to have the information repeated and to adjust the volume.

**NAVIGATOR VOICE MESSAGE MUTING (NAV MUTE):** press the NAV key (20).

**NAVIGATOR VOICE MESSAGE ON** press the NAV key (20).

#### **Main menu page (MAIN)**

**PAGE ACTIVATION:** press the MAIN key (17) briefly.

#### **Radio menu page (AUDIO)**

**PAGE ACTIVATION:** press the AUDIO key (18) briefly.

**AUDIO SOURCE PAGE (FM1, FM2, FM3, LW, MW, CD - if inserted, CD-Changer - if installed):** press the SRC key (15) repeatedly.

**SOUND PARAMETERS SETTING:** "Audio Setup" function.

#### **Radio**

**WAVEBAND SELECTION:** press the SRC key (15) repeatedly.

**MANUAL STATION SEARCH:**

"Frequency" function. Turn the right-hand knob (22) in a clockwise or counter-clockwise direction to begin the manual search of the higher or lower frequency.

**AUTOMATIC STATION SEARCH:** "Frequency" function. Press key (11) or (12) to begin the automatic search of the station, in a lower or higher frequency, respectively.

**AUTOMATIC STATION SAVING:**

"Autostore" function.

**MANUAL STATION SAVING:** keep one of the keys numbered from "1" to "6".

**STORED STATION SELECTION:** briefly press one of the keys numbered from "1" to "6".

**AUTOMATIC SEARCH FOR THE STRONGEST FREQUENCY FOR THE STATION YOU ARE LISTENING TO:** "TA/AF" function. Press the right-hand knob repeatedly until the "AF" code appears on the display.

**SEARCHING ALL NETWORKS:** "LOC/DX" function. Press the right-hand knob (22) repeatedly until the "DX" code appears on the display.

**SEARCHING ALL NETWORKS WITH THE STRONGEST SIGNALS:** "LOC/DX" function.

Press the right-hand knob (22) repeatedly until the "LOC" code appears on the display.

**STEREOPHONIC RECEPTION:** "St/Mono" function. Press the right-hand knob (22) repeatedly until the "STEREO" code appears on the display.

**MONOPHONIC RECEPTION (WEAK NETWORKS):** "St/Mono" function.

Press the right-hand knob (22) repeatedly until the "MONO" code appears on the display.



**CD player**

CD SOURCE SELECTION (if an audio CD is inserted): press the SRC key (15) repeatedly.

PREVIOUS TRACK SELECTION: press the key (11) briefly.

NEXT TRACK SELECTION: press the key (12) briefly.

CD PLAY/STOP: press the key (10) briefly.

PAUSE: press the key (10) at length.

PLAY THE FIRST 10 SECONDS OF ALL TRACKS: "Scan" function.

RANDOM TRACK SELECTION: "Shuffle" function.

SELECTING THE INFORMATION

DISPLAYED: first select the "CD setup" function and then the "Display" function.

CONTINUOUS PLAYING OF A SINGLE TRACK: first select the "CD setup" function, then the "Repeat" function, followed by the "Single" option.

CONTINUOUS PLAYING OF THE ENTIRE CD: first select the "CD setup" function, then the "Repeat" function, followed by the "Complete" option.

CD EJECTION: press the key (26).

**CD-Changer (optional)**

CDC SOURCE SELECTION: press the SRC key (15) repeatedly.

NEXT CD SELECTION: press the key (7) briefly.

PREVIOUS CD SELECTION: press the key (9) briefly.

PREVIOUS TRACK SELECTION: press the key (11) briefly.

NEXT TRACK SELECTION: press the key (12) briefly.

CD PLAY/STOP: press the key (10) briefly.

PAUSE: press the key (10) at length.

PLAY THE FIRST 10 SECONDS OF ALL TRACKS ON THE CD YOU ARE

LISTENING TO: "Scan" function.

RANDOM TRACK SELECTION OF THE

CD YOU ARE LISTENING TO: "Shuffle" function.

SELECTING THE INFORMATION

DISPLAYED: first select the "CDC setup" function and then the

"Display" function.

CONTINUOUS PLAYING OF A SINGLE TRACK: first select the "CDC setup" function, then the "Repeat" function,

followed by the "Single" option.

CONTINUOUS PLAYING OF THE ENTIRE CD YOU ARE LISTENING TO: first select the "CDC setup" function, then the

"Repeat" function, followed by the "CD" option.

CONTINUOUS PLAYING OF ALL THE CDs IN THE LOADER: first select the "CDC setup" function, then the "Repeat" function, followed by the "Complete" option.

**Navigation (NAV)**

ACTIVATION: insert the navigation CD-ROM; with the CD-ROM inserted, press the NAV key (20) briefly.

VIEW FIRST MENU PAGE: with the navigation function page displayed, press the right-hand knob (22).

VIEW OTHER MENU PAGES: select the "Other menus" item available on each page of the menu.

ENTER DESTINATION: on the first page of the menu, select the "Address" function.

LIST OF THE LAST 10 DESTINATIONS

ENTERED: on the first page of the menu, select the "Last destinations" function.

ENTER DESTINATIONS IN THE DIRECTORY: on the first page of the menu, select the "Directory" function and assign a "Name" to the destinations.

TEMPORARY STOP OF NAVIGATION: on the first page of the menu, select the "Stop NAV" function.

ERASING STORED DESTINATIONS: select the "Delete destination" function on the first page of the menu.

**SEARCH FOR POINTS OF GENERAL INTEREST:** on the second page of the menu, select the "Points of interest" function.

**TO RECEIVE INFORMATION ABOUT PUBLIC UTILITIES:** on the second page of the menu, select the "RDS TMC" function.

**DESTINATION SELECTION DIRECTLY ON THE GEOGRAPHICAL MAP:** select the "Atlas" on the second page of the navigation menu and locate the destination using the options "↔" (shift horizontally), "↕" (shift vertically) and "Scale" options.

**REQUESTING A ROUTE OTHER THAN THE ONE PROPOSED:** select the "Alternate route" function on the second page of the menu.

**SELECTING THE INFORMATION DISPLAYED:** select the "Change display" function on the second page of the menu.

**GRAPHIC SETTING SELECTION:** select the "Map options" function on the third page of the menu.

**SHORTEST ROUTE SELECTION:** first select the "Route options" function on the third page of the menu and then the "Route type" function. Set the "Shortest distance" option.

**FASTEST ROUTE SELECTION:** first select the "Route options" function on the third page of the menu and then the

"Route type" function. Set the "Shortest time" option.

**AVOIDING HIGHWAYS:** first select the "Route options" function on the third page of the menu and then the "Highway" function. Set the "NO" option.

**EXCLUSION OF VOICE INSTRUCTIONS (MUTE NAV):** press the NAV key (20).

**RESTORING VOICE INSTRUCTIONS:** press the NAV key (20).

#### ***On-board computer (TRIP)***

**PAGE ACTIVATION:** press the TRIP key (21) briefly.

**BACK TO MAIN MENU PAGE:** press the ESC key (23).

**DATA READOUT SINCE THE LAST MANUAL RESET:** data function "A"

**DATA READOUT SINCE THE LAST AUTOMATIC RESET (key on STOP for more than 2 hours):** press the TRIP key (21) again to select the Data function "B".

**MANUAL RESET FOR DATA FUNCTION "A":** select the "Reset" function.





## Sound system

The Maserati Info Center system also includes a radio with a CD player, a CD-changer (optional).

The sound system in the car consists of:

- a tweeter speaker **A** and a woofer speaker **B** on each door panel

- two mid-range loudspeakers **C** on the rear side valance panels

- two subwoofer loudspeakers **D** on the back shelf

4

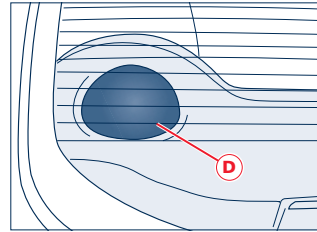
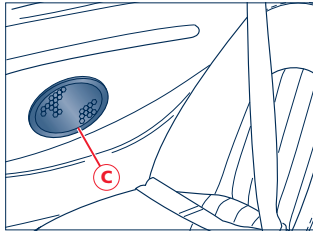
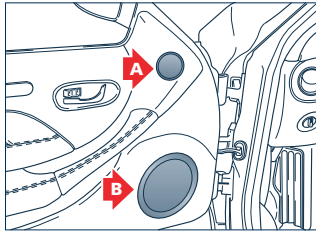

100

Sound system

- built-in aerial in the rear window
- aerial incorporated in the windshield
- music player/card reader for single-CD/GPS navigator in the central console **E**

- CD-changer **F** (optional) positioned on the left-hand side of the trunk.

**WARNING:** The cable for installation of the CD player in the luggage compartment is supplied only in cars equipped with CD-changers.

#### Diversity system

It consists of two combined aerials, that are activated alternatively, depending on the one that better receives the signal.

#### High output stereo system (optional)

The high-output stereo system is equipped with:

- a 4-channel amplifier
- specific high-output speakers.

The nominal power is approximately 200 Watt with a peak of 400 Watt. The amplifier is housed on the left-hand side of the luggage compartment and it is protected by a fuse located on the amplifier itself. You are advised to contact your **Authorized Maserati Dealer** to have the fuse replaced.

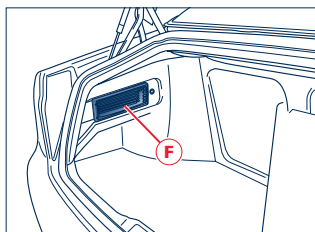
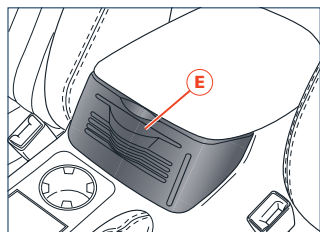



## Air conditioning and heating system

4

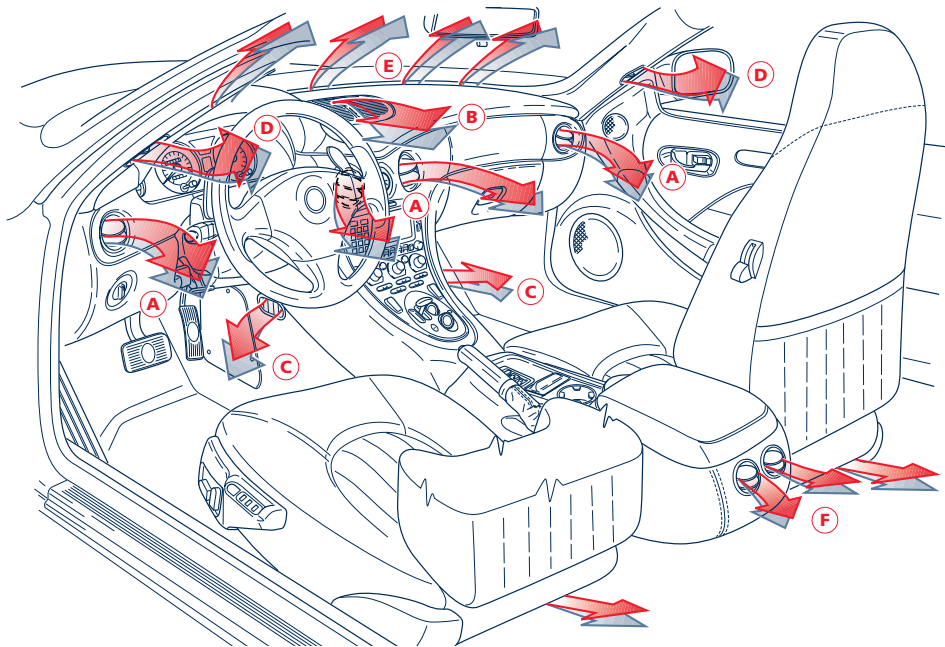

102

Air conditioning and heating system

- A - Dashboard central and side vents
- B - Dashboard upper vent
- C - Dashboard lower vents
- D - Side window demisting/defrosting vents
- E - Windshield demisting/defrosting vents
- F - Rear vents

**Upper dashboard outlet**

Turn control **G** to open/close the upper outlet and adjust air flow.

**Central and side dashboard vents**

Press the tab in point **H** to open the central and side outlets. Turn the vent with open tabs to obtain the required air flow direction.

**Front windshield pillar vents**

Vents **L** positioned on the windshield pillars are fixed and directed for demisting/defrosting the front side windows.

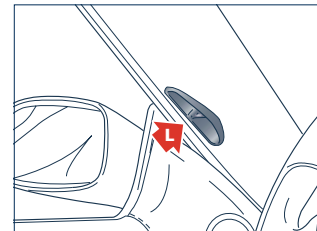
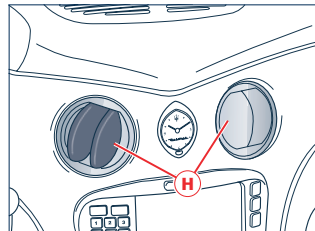
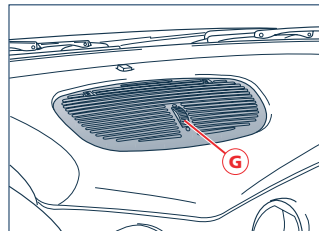

*Air conditioning and heating system*





#### Lower dashboard vents

Vents **M** are positioned on the lower dashboard sides, and they cannot be aimed.

#### Rear vents

The rear seat air-conditioning and heating vents are positioned at the end of the central console.

To open the vents, press the fin at point **N**.

The airflow can be directed as desired by turning the vent with the fins open.

4

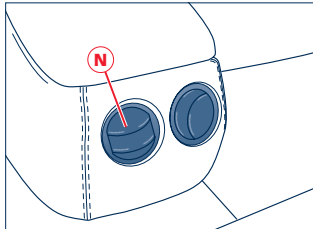
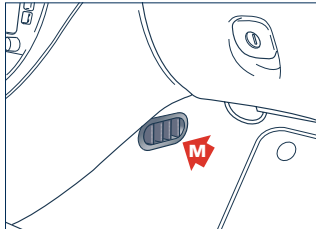

104

Air conditioning and heating system

### Automatic air conditioning and heating controls

- 1) Knob for setting the required "comfort" temperature
- 2) Air distribution knob
- 3) Knob for adjusting fan speed and switching off the system
- 4) Pushbutton for air recirculation activation/deactivation

5) ECON pushbutton for deactivation of the ventilation compressor

- 6) Display for system operating conditions (fan speed, "Comfort" temperature set and air distribution).

### Equivalent temperature

The system allows automatic and manual control of the temperature and humidity inside the passenger compartment. The temperature set with the controls is called "equivalent temperature" and it corresponds to a comfortable climate based on the actual temperature inside and outside the passenger compartment.

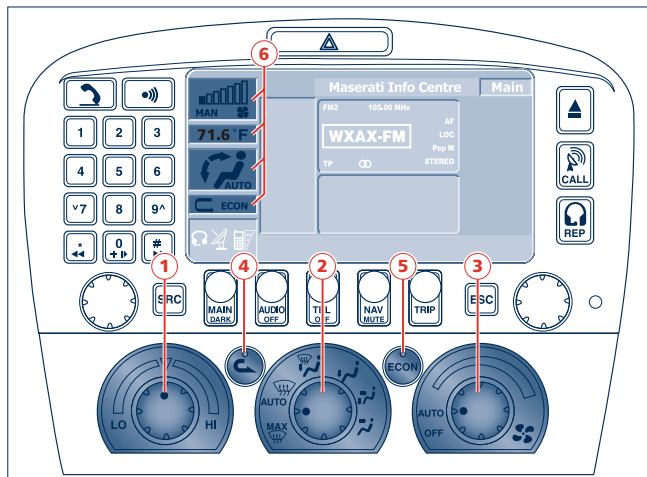

Air conditioning and heating system





## Description of controls

### 1) Control for setting the required "equivalent" temperature

Sets the desired temperature inside the passenger compartment. The "LO" and "HI" functions (the minimum and maximum temperatures respectively) are at the outermost positions.

### 2) Air distribution control

This performs the following functions according to its position:

**AUTO** air distribution is automatically selected by the system. In addition, the heated rear window and the side rear view mirror resistors (and the relative LED on the button) switch on automatically for a preset time.

 Activates the windshield and side window demisting and/or defrosting function.

 Airflow towards the windshield and front side windows.

 Airflow distribution between the windshield/front side windows and the lower section of the passenger compartment.

 Main air flow towards the lower section of the passenger compartment and secondary air flow towards the windshield/front side windows.

 Air flow distribution between the upper central vent, the central, side and rear vents and the lower section of the passenger compartment.

 Air flow towards the upper central vent, the central and side vents on the dashboard and the rear vents.

### 3) System deactivation and fan speed adjustment control

Turning the control to the left or the right respectively decreases or increases the fan speed and therefore the amount of air blown into the passenger compartment, thereby maintaining the equivalent temperature requested.

**AUTO** fan speed is adjusted automatically by the system.

**OFF** the air-conditioning system is off and **OFF** appears on the display.

### 4) Activation/deactivation button for air re-circulation

When re-circulation is activated, the air flow comes from within the passenger compartment. Visually the LED on the button switches on and the symbol  appears on the display. To deactivate the re-circulation function press the button again; the LED on it switches off. According to the climatic conditions, re-circulation can be inserted automatically by the system if it has not previously been activated/deactivated manually.

**WARNING:** Depending upon the system operation (to heat or cool the passenger compartment) the recirculation function makes it possible to reach the desired conditions more rapidly. On particularly damp/cold days you are advised not to use this function since this could cause the windshield to mist up. This function is recommended during traffic jams, especially in tunnels, to avoid polluted air entering the compartment. The prolonged use of this function is however to be avoided when there are many passengers.

### 5) Deactivation button for the air-conditioning system compressor

Pressing the **ECON** button disables the air-conditioning system compressor function. When this is disabled the LED on the button switches on and **ECON** appears on the display. To deactivate the **ECON** function press the button again; the LED on it switches off. The air is cooled and/or dehumidified according to the temperature set.

**WARNING: It is not possible to have air flow in the passenger compartment at a lower temperature than the outside air temperature when the compressor is switched off; Under special environmental conditions the windows could fog up quickly.**

### Description of operating strategies

During automatic operation, the system controls the following functions:

- temperature of the air entering the compartment
- fan speed (stepless change)
- air distribution
- air recirculation function
- ventilation compressor activation.

It is however possible to manually intervene on the following functions:

- fan speed
  - air distribution
  - air recirculation function
  - ventilation compressor activation.
- Functions activated manually have priority over automatic functions and are stored in the memory until automatic control is reactivated.

With one or more manually operated functions, air temperature adjustment continues to be automatically controlled by the system, except with deactivated compressor: under this condition, the temperature of the air entering the compartment shall not be lower than outside temperature.

The system can be operating under one of the following conditions:

- automatic control of the fan speed and air distribution (**AUTO** message switched on in both sectors of the display)
- automatic control only of the fan speed or air distribution, according to the preferences of the user (**AUTO** and **MANUAL** messages switched on in the display sectors, indicating automatic and manual operation)
- manual operation, in which the user directly controls fan speed and air distribution (**MANUAL** message switches on in both sectors of the display).

When the **ECON** button is pressed, the ventilation compressor is switched off. With deactivated compressor, the air entering the compartment cannot be cooled or dehumidified and the recirculating air function is automatically deactivated to avoid window steaming. Pressing again the **ECON** button with disabled compressor, activates the previous operating conditions.

Turn knob **3** to **OFF** to switch off the air conditioning and heating system; no air will be delivered to the passenger compartment that remains isolated from the outside environment.

*Air conditioning and heating system*





**WARNING:** When the air conditioning and heating system is off (knob 3 on OFF) air enters the passenger compartment and thus, under certain environmental conditions or with more than one person in the car, the windows could fog up quickly.

If air distribution is selected manually using knob 2, the simple automatic mode is obtained: that is, the system selects fan speed and air mixing to reach the requested "comfort" temperature, however, without changing the air distribution selected manually.

4

Pressing button 4, corresponding to the air recirculation function, automatically reactivates the compressor, if it has been manually deactivated, in order to prevent the windows from fogging up.

During the automatic operation the system can automatically activate the recirculating air function or deactivate the ventilation compressor to cool/heat the compartment or to demist/defrost windshield and front side windows.

**WARNING:** When the engine is started, the system keeps the settings selected manually prior to switching off.

### Dust/pollen air cleaner

The ventilation and heating system is provided with an air cleaner which combines the mechanic air filtering function with an electrostatic effect in order to help clean the air entering the compartment from dust, pollen, etc.

Filtering is performed with both outside air intake (recirculating air function off) and recirculating air intake conditions (recirculating air function on).

Have your air cleaner replaced at least once a year at your **Authorized Maserati Dealer** (possibly in spring or early summer).

In the event of use of the car primarily in polluted or dusty areas, more frequent air filter replacement is advisable.

**WARNING:** Failure to replace the air cleaner can reduce the ventilation and heating system efficiency considerably.

### Specific luggage set (optional)

The specific luggage set allows the passengers to use the vehicle luggage compartment capacity very efficiently.





## Using the vehicle

Starting the engine	112
Manual gearbox	114
“Cambiocorsa” gearbox	115
Using the brakes	122
Use of the engine	123
Constant speed control (Cruise Control)	125
Electronic suspension (optional)	128
Headlights	131
Driving conditions	132
Pollution control devices	136
Parking	138
Tires	139





## Starting the engine



Keep the brake pedal pressed when starting the engine.



It is dangerous to operate the engine in a closed space. The engine consumes oxygen and discharges carbon dioxide, carbon monoxide and other toxic gases.

**WARNING:** Before starting-up the vehicle, deactivate both the electronic alarm by pressing the radio-controlled key and the electrical devices with high power absorption (air-conditioning, heated side window, headlights etc.).

**WARNING:** Do not start the engine if the fuel in the tank is low.

### Procedure for manual gearbox version

- 1) Ensure that the handbrake is engaged.
- 2) Move the gearshift to neutral.
- 3) Press down the clutch without pressing the accelerator.

4) Turn the ignition key to the **AVV** position and release it as soon as the engine starts.

If the engine does not start at the first attempt, move the key back to **STOP** before trying again.

Do not leave the ignition key in the **MAR** position with the engine off.

### Procedures for the "Cambiocorsa" gearbox

- 1) Ensure that the handbrake is engaged and that the doors are closed.
- 2) Keep the brake pedal pressed when starting the engine.
- 3) Do not press the accelerator pedal.
- 4) Put the gearshift in neutral, by holding both the **UP** and **DOWN** levers towards the steering wheel, and ensure that the gear indicator shows **N** and that it is not flashing.
- 5) Turn the ignition key to the **AVV** position and release it as soon as the engine starts. Do not keep the key turned to the **AVV** position for a long time. If the car does not start, turn the key back to the **STOP** position and wait until the gear indicator switches off before repeating the procedure.

The engine can be started even with a gear engaged. In fact, with the key in

the **AVV** position (with the brake pedal pressed), the system allows the clutch to open and the transmission to be shifted to neutral. Then the starter motor receives clearance to perform the start-up. This step usually requires about one second. With very low temperatures, this step could take a slightly longer time.

If the gearbox is instead in the **N** position, starting is immediate.

When the engine has started up, release the key and it will automatically return to the **MAR** position.

If the car does not start, turn the key back to the **STOP** position and wait until the gearshift display switches off and then repeat the entire procedure.

### How to warm up the engine after starting

Start driving slowly, with the engine running at average speed. For the first few miles do not run the car at maximum performance. You are advised to wait until the water temperature has reached 122°-140°F (50° - 60°C).

### Emergency starting with auxiliary battery

If the battery is discharged, the engine can be started using another battery having the same or slightly higher capacity than the flat one.

Follow the below instructions:

- 1) Connect the positive terminals (+) of the two batteries with a jumper cable.
- 2) Connect the negative terminals (-) of the two batteries with a jumper cable.
- 3) Start the engine.
- 4) When the engine starts, remove the jumpers cables in reverse order.

If the car does not start after several attempts, contact your **Authorized Maserati Dealer**.



Do not carry out this procedure if you do not have experience: incorrect maneuvers can cause high electrical discharges and even cause the battery to explode.



Do not to approach the battery with open flames or lit cigarettes or sparks because of risk of explosion and fire.

**WARNING:** Do not use a battery-charger for emergency starting under any circumstances. This could damage the electronic systems, particularly the control units performing the ignition and fuel supply functions.

### Starting with inertia maneuvers (push-start, etc.)

**WARNING:** Since the car is catalyzed, under no circumstances should it be started by pushing, towing or on downward slopes. These actions could cause fuel to flow into the catalytic converter and damage it beyond repair.



Remember that when the engine is not started, the brake servo and power steering systems are not activated and therefore the effort required on the brake pedal and steering wheel is much greater.

### Turning off the engine

With the engine idling, rotate the ignition key to the **STOP** position. A "burst" on the accelerator pedal before turning off the engine has no purpose and increases fuel consumption.





## Manual gearbox

The manual gearbox has six gears plus a reverse gear, all of which are synchronized. The gearshift lever is in the center of the central console. To engage the gears, press the clutch pedal down and shift the gear lever to one of the positions in the diagram (the layout is also shown on the lever knob).

When downshifting, make sure that you do not exceed the maximum speed allowed for the engine. Engage the reverse gear only with the car stationary. To engage the reverse gear, shift the lever to the left overcoming the resistance of the reaction spring.

 In order to shift gears correctly, you need to press the clutch pedal down fully: the area under the pedal board therefore must be free of any obstacles. Check that any mats are always flat on the floor and do not interfere with the pedals.

5

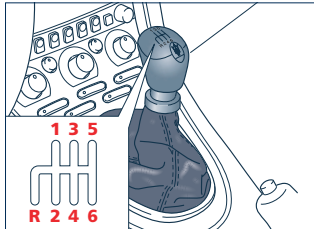

Manual gearbox

114

## "Cambiocorsa" gearbox

The "Cambiocorsa" gearbox is controlled by the levers on the steering wheel for gear-shifting, by the lever on the central console for engaging the reverse gear and by the pushbuttons to activate the "automatic transmission" and "low grip" functions. The "Cambiocorsa" gearbox controls are the following:

- A - Lower gear engagement lever - DOWN
  - B - Upper engagement lever - UP
  - C - Reverse and 1st gear engagement lever
  - D - "Automatic transmission" function switch
  - E - Low grip" function switch.
- The display F on the instrument panel indicates the gear currently engaged,

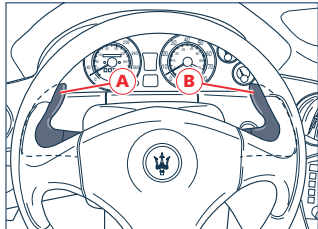



whereas the warning light  on the multi-function display indicates a system failure. When the "automatic transmission" and "low grip" functions are switched on, the **AUTO** and **ICE** messages light up on the multi-function display, respectively. An insufficient oil level in the gearbox is indicated by the **LEVEL** message lighting up on the multi-function display.

### Starting the ignition system

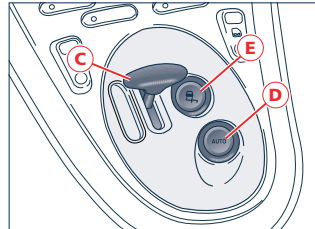
Turn the ignition key to the **MAR** position to activate and light up the gearbox display F. The respective failure warning light  will also switch on and then switch off if no malfunctioning is detected after several seconds. The gear currently engaged will remain highlighted on the display.



**WARNING:** It is sometimes possible to hear a buzzing coming from the gearbox unit when the driver's door is opened; this is produced by pre-ignition procedures. The failure warning light  may also flash for a brief period of time (approx. 10 sec.) and then switch off. The system completes the "ignition" stage and then it is correctly activated. Avoid entering any commands to the system during this stage.

 **If the warning light  continues to flash without switching off, re-start the system after having switched it off. If this malfunctioning persists, contact your Authorized Maserati Dealer for service.**

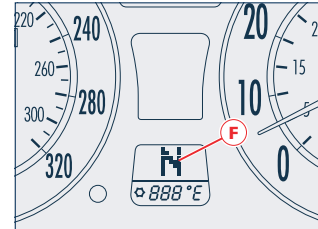

"Cambiocorsa" gearbox





If the warning light  remains on, there may be a system multifunction. This status is also indicated by a beep when the key is brought to the **MAR** position. Contact your **Authorized Maserati Dealer** for service

#### Operation with the engine switched off

After completing the "system start-up" stage, the gear currently engaged will appear on the display:

- **N** (Idle)
- **R** (Reverse gear)
- **1** (1<sup>st</sup> gear)
- **2** (2<sup>nd</sup> gear), etc.

5



"Cambiocorsa" gearbox

116

If the indication is flashing (which can also occur with **N**), it means that the gear is not perfectly engaged or disengaged; shift it to neutral (**N**) and then to the desired gear.



**If a horizontal dash appears on the display, there may be system multifunction.**

With the engine switched off, all gears can be engaged, including the neutral (**N**); keeping the brake pedal pressed, you must proceed as follows:

- **N** (Neutral): pull both levers found behind the steering wheel.
- **R** (Reverse gear): raise and pull lever **C** away from you.
- 1st gear engagement: move the lever **C** (Reverse) forwards.
- Up-shifting: pull the **UP** lever (**B**) towards the steering wheel.
- Downshifting: pull the **DOWN** lever (**A**) towards the steering wheel.



**To engage the reverse gear, keep lever C pulled away from you, until the R signal appears on the display.**



**To engage the 1st gear using the reverse lever C, you must keep it pressed towards the front until the number "1" appears on the display.**

**WARNING:** Release the **UP**, **DOWN** and **R** levers immediately after the gearshift request. A prolonged maneuver could make the failure warning light  and sound signal switch on. Do not operate the system with the engine switched off to prevent discharging of the battery. Avoid shifting of gears with the engine off, to prevent overheating of the system.

#### Driving the car

With the engine started, the car stopped and the brake pedal pressed, pull the right-hand lever **UP** towards the steering wheel to engage the 1st gear, or move the lever **C** forwards. Release the brake pedal and press the accelerator to start off.

With the engine on and the car stopped, you can shift directly from the 1<sup>st</sup> or 2<sup>nd</sup> gear to **R** (reverse) by moving the lever **C**, which will also allow you to return to the 1<sup>st</sup> gear. This latter operation is also possible by pulling the right-hand lever **UP** towards the steering wheel.

**WARNING:** Engagement of the reverse gear is accompanied by a safety sound signal, which sounds intermittently for the entire time in which it is engaged.

When shifting from reverse to 1<sup>st</sup> gear, if the system automatically engages the 2<sup>nd</sup> gear, it indicates that a problem has occurred with the 1<sup>st</sup> gear. Therefore, this is not a failure, as it falls into the logic of the system operation. For the same reason, the system automatically engages neutral (N) in case of interference when shifting from 1<sup>st</sup> gear to reverse.

During prolonged parking periods with the engine running, it is advisable to keep the gearshift in neutral (N).

**WARNING:** On certain occur on downhill routes, if you leave the car in neutral (N), when you request a higher gear UP, the gear engaged will depend on the current speed of the car.

For your safety reasons, the system activates the sound signal and automatically sets the neutral gear (N) when the car is stopped, the engine is on and the gear is engaged:

- if the brake pedal or the accelerator is not used for over 1 minute
- if the brake pedal is pressed for more than 10 minutes

- if the door is opened without pressing the brake pedal or the accelerator
- if the engine lid is opened.

**WARNING:** The warning buzzer is activated also if the clutch overheats during the starting "pickup" maneuver.

In this case, the departure procedure must be "forced", avoiding hesitation or keeping the car stopped and applying on the brake pedal after having released the accelerator.

#### Hill Holder strategy

The Hill Holder system helps the driver during start-offs on uphill stretches. It activates only after a stop when the brake pedal is released, keeping the vehicle stopped for a maximum time of 1.2 seconds, thereby allowing the driver to have enough time for moving from the brake pedal to the accelerator pedal.

**WARNING:** when the system is active, the driver may perceive a stiffening of the brake pedal upon pressing it. This must not be considered as a malfunction but as a normal consequence of the system operation.

#### Important

- With the car stationary and a gear engaged, keep the brake pedal pressed until departure.
- Do not "modulate" the accelerator pedal during departure stages.
- Engage the reverse gear only when the car is at a full stop and with the brake pedal pressed.
- In the case of uphill stops, do not use the "departure maneuver" to keep the car still - use the brake and the accelerator pedal only when you wish to depart.
- Deactivation of the MSP device signifies losing control of the traction wheel slip; in SPORT mode traction wheel slip can be controlled.





### Up-shifting "UP"

Use the right-hand **UP** lever, without releasing the accelerator pedal. The **UP** shifting is not accepted if the gear engagement requested forces the engine underrunning or if the engine is already in the process of completing an up-shift **UP** (overrunning). Gear-shifting is faster if requested with the accelerator pressed down to the floor and with the engine exceeding 5,500 revs/min.

In any case, it is best to:

- Change gears without releasing the accelerator pedal if it is pressed.
- wait until one gearshift is completed before requesting the next one, thereby avoiding a rapid sequence of multiple requests.

### UP for overrunning speed rate

The system switches to an upper gear "automatically" if the engine reaches a value approaching the "overrunning rate" and the accelerator pedal is pressed. This condition does not occur with the system in the "SPORT" mode.

### Downshifting "DOWN"

Use the left-hand **DOWN** lever, even without releasing the accelerator pedal.

The **DOWN** shifting is not accepted if the gear requested forces the engine overrunning, depending upon the gear requested, or if a **DOWN** shift is already in progress due to underrunning.

In any case, it is best to:

- Shift gears without releasing the accelerator pedal if it is pressed.
- In the case of a **DOWN** shift request to pass a car, where more rapid acceleration is required, press the accelerator pedal just before moving the lever.
- Wait until a gearshift has been completed before requesting another one, avoiding multiple requests in rapid sequence.

### DOWN for underrunning speed rate

The system shifts down the gears "automatically", if the engine runs below the minimum speed rate set at 1,300 r.p.m.

The **DOWN** command is ignored if gear-shifting due a low speed rate is in progress.

### Requesting neutral (N)

If necessary, it is possible to request neutral (**N**) at any speed. Subsequently, if the **UP** lever is used, the system switches to a gear in keeping with the speed of the car.

### Stopping the car

When the car is stopped, the system automatically switches to 1st gear (unless N has already been selected previously).

With the car stopped and the engine running, keep the brake pedal pressed until you are ready to depart again.

### Switching off the engine and the system

The engine can be stopped both with the gear lever in N and in 1<sup>st</sup>, 2<sup>nd</sup> or R position.

After turning the key from the **MAR** position to the **STOP** position, the display remains on for several seconds, indicating the current gear. If the gearbox is in neutral (N) a buzzer is activated.

For greater protection against sudden movements of the car:



**Never leave the car with the gearshift in neutral (N). Switch to 1<sup>st</sup> gear or reverse, ensure that the display is not flashing and always engage the handbrake. Do not leave the car with the engine running.**



**Do not remove the key with the car moving! The system (and thus the display) would remain activated but operating irregularly until the car stops and the steering wheel would lock automatically at the first turn of the wheel.**

In this case, the failure  warning light lights up and before driving once again, the system (and thus the display) must be switched off and the "system start-up" phase repeated.

In any case, it is best to:

- Switch off the engine and the system keeping the brake pedal pressed.
- Do not request a gearshift while the system is turning off.

### Other system functions

#### "Low-grip" mode

This mode can be used on particularly slippery roads (snow, ice) and it is activated/deactivated by pressing switch E. This will make the respective ICE indicator on the instrument panel light up.

In the "low-grip" mode, the system uses the 2<sup>nd</sup> gear instead of the 1<sup>st</sup> gear. Therefore, with the car stopped and the engine running, when the **UP** lever is moved from neutral or reverse gear, or when the car is stopped, the system automatically shifts to 2<sup>nd</sup> gear. When in 2<sup>nd</sup> gear, the **DOWN** request from the lever is ignored. When driving, the system automatically switches to the upper gear if the engine reaches the pre-established speed rate (3,200 r.p.m.). The "low-grip" mode has priority over the other functions ("automatic gearshift" and "SPORT") and it assists the MSP system.





 **A DOWN request from 6th to 5<sup>th</sup> gear will only be accepted if the engine speed rate in 5<sup>th</sup> gear proves to be lower than 3,200 r.p.m. As the "low-grip" mode can be activated at any time and the system limits the engine's speed rate to 3,200 r.p.m. in all gears except for the 6th, unrequested UP shifts could take place.**

It is a good rule to switch off the other operating modes ("automatic gearshift" and "SPORT") before you select the "low-grip" mode.

#### **"Automatic gearshift" mode**

This mode is activated/deactivated by pressing switch **D**. The **AUTO** message will light up on the instrument panel and the system will automatically adjust the gears **UP** and **DOWN** according to the car speed, the engine speed rate and the driver's request for torque/power.

**WARNING:** The "automatic gearshift" mode has priority over the "SPORT" mode. Therefore, if the **AUTO** pushbutton **D** is pressed when in the "SPORT" mode, even if the "SPORT" indicator remains on, the **AUTO** indicator will light up and the system will operate in the "automatic gearshift" mode, while keeping the suspensions in the "SPORT" position in any case.

It is possible to return to the "normal" mode (or "SPORT" mode, if this mode was active) by requesting a gear-shifting or keeping switch **D** pressed until the "AUTO" indicator switches off.

When the car is stopped, the request for **N**, **1<sup>st</sup>** or **R** does not cause a change from the "automatic transmission" mode to the "normal" mode.

It is a good rule to switch off the other operating modes before you select the "automatic transmission" mode.

#### **"SPORT" mode**

This mode is activated by pressing switch **G**. The respective **SPORT** indicator will light up on the instrument panel.

To return to the "normal" mode from the "SPORT" mode press the switch again.

As the "SPORT" mode has lower priority with respect to the "low-grip" and "automatic transmission" modes, if the latter are already active when you activate the "SPORT" mode, the system will ignore the command even though the respective warning light switches on.

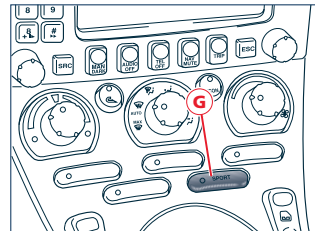



The "SPORT" mode is characterized by a stiffening of the suspension and faster gearshift compared to gear-shifting in the "normal" mode.

Gear-shifting is "faster" if requested with the accelerator pedal pressed down to the floor and when exceeding about 7,000 r.p.m. Under these conditions, even on dry roads, the driving wheels could start to skid (particularly in low gears). DOWN shifts with the accelerator pedal released, will have a braking effect approaching the skidding limit of the driving wheels on dry asphalt. Under sporty driving conditions with gearshifts at high engine speed rates, double-clutching when down-shifting is performed automatically.



Do not use the "SPORT" mode on roads with low or medium "grip" conditions (e.g., ice, snow, or wet roads) as the driving wheels could skid during gearshifts.

It is a good rule to switch off the other operating functions ("low-grip" and "automatic transmission") before you select the "SPORT" mode.

**WARNING:** In the event of malfunctioning of the control lever unit, in addition to activating the buzzer and switching on the failure  warning light, the system enables the "automatic transmission" mode and any gearshift command, including the request for N and R, will be ignored.

**WARNING:** If the malfunctioning persists, contact your **Authorized Maserati Dealer** as soon as possible for service.





## Using the brakes

**WARNING:** In order to run in the brake pads and discs suitably, avoid sudden and sharp brakings during the first 190 miles (300 Km).

ABS is a component of the braking system that offers two basic advantages:

- It helps avoids locking of the wheels and thus skidding during emergency braking and especially under low grip conditions.
- It makes it possible to brake and steer at the same time in order to avoid unexpected obstacles or to direct the car where desired when braking, this is in keeping with the physical limits of the tire's side grip.

You will note a light vibration of the brake pedal during emergency braking or braking under low grip conditions. This is a sign that the ABS is operating. Do not release the pedal but continue to press it to give continuity to the braking action.

The ABS helps prevent the wheels from locking, but it does not increase the physical grip limits between the tires and the road. Therefore, even if your car is fitted with ABS, always ensure to keep to a safe distance from the car in front of yours and reduce your speed when entering a curve.

## Use of the engine

### Breaking-in

Today's modern methods of production afford high precision in the construction and coupling of components. However, the moving parts do undergo a breaking-in process, basically in the first hours of the car's operation.

### Engine and transmission

Avoid exceeding 5000 r.p.m. for the first 600 miles (1,000 km). After starting the car, do not exceed 4,000 r.p.m. until the engine has warmed up sufficiently (water temperature: approx. 150-160 °F (65-70 °C)).

Do not keep the car at a constant high speed rate for a prolonged time.

### Driving the car

Never travel with the Tachometer indicator approaching the peak r.p.m. not even downhill.

When the Tachometer indicator is approaching the peak r.p.m. (red-colored line), take precautions to avoid exceeding that limit.

**WARNING:** Under normal operating conditions, no red light warning indicators on the instrument panel should be displayed. When they switch on, they indicate a problem in the respective system.

Ensure proper operation of the various devices by checking the respective control instruments.

**WARNING:** Continuing to drive when a red warning light switches on could cause serious damage to the car and affect performance.



**Do not travel downhill with the engine off because the servo brake is not operating due to lack of vacuum: after several brakings, the system loses almost all efficiency.**





### Engine control system OBDII

This system continuously monitors the components of the vehicle related to emissions; it also warns the user about the deterioration condition of the components themselves, by means of the warning light  on the instrument panel.

The objective is the following:

- keep engine systems operating efficiently
- indicate when a problem causes an increase in emissions exceeding the threshold established by federal regulations
- indicate the need for replacement of deteriorated components.

In addition, the system includes a diagnostics connector that can be interfaced with suitable instruments.

This makes it possible to read the error codes stored in the control unit, together with a set of specific parameters for engine operation diagnostics, in compliance with OBDII rules.

**WARNING:** When the ignition key is turned to the **MAR** position, if the  warning light does not switch on or if it switches on while driving, contact your **Authorized Maserati Dealer** as soon as possible.

**WARNING:** After the problem has been eliminated, your **Authorized Maserati Dealer** personnel is required to perform tests of the system and if necessary, also road tests.

## Constant speed control (Cruise Control)

### General information

The electronic cruise control makes it possible to drive the car at the desired speed without pressing the accelerator pedal. This helps reduce driving fatigue, especially on long trips because the speed stored in the memory is kept constant automatically.

**WARNING:** The device can only be switched on at speeds exceeding 18 mph (30 km/h) and it switches off automatically when the brake pedal is pressed.

 **The speed control must only be activated when traffic and the route permit a constant speed to be maintained safely for a sufficiently long distance.**

### Controls

The speed control is activated by the switch **A**, by the ring band **B** and by the pushbutton **C (RCL)**.

The switch **A** has two settings:

- **OFF** the device is deactivated in this position;
- **ON** the normal operating position of the device. When the device is switched on, the message **CRUISE** lights up on the instrument panel display.

The ring band **B** is used to store the car speed in the memory and to maintain it, or to increase or decrease the speed stored.

Turn the ring nut **B** to the (+) position to save the speed reached or to increase the speed stored in the memory.

Turn the ring nut **B** to the (-) position to decrease the speed memorized. Each time the ring nut **B** is moved the speed increases or decreases by about 1 mph. When the ring nut is kept turned, the speed varies continuously. When a new speed is reached, it will automatically remain constant. Pushbutton **C (RCL)** is used to restore the speed saved in the memory.

**WARNING:** When the ignition key is turned to **STOP** or switch **A** is in the **OFF** position, the speed saved is erased and the system switches off.

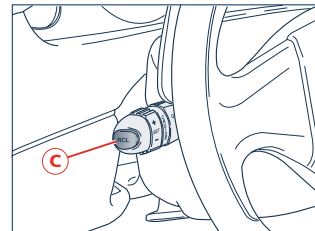
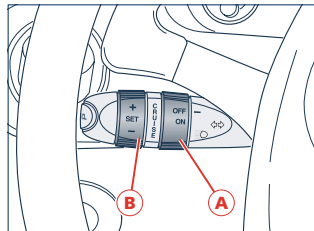

Constant speed control (Cruise Control)





### Storing a speed

Turn switch **A** to the **ON** position and reach the desired speed of the vehicle in a normal manner. Turn the ring nut **B** to (+) for at least three seconds and then release it. The car speed is saved and the accelerator pedal can then be released.

The car will proceed at the constant speed stored in the memory until the brake pedal is pressed.

If necessary, (for example, to pass another vehicle), you can accelerate by simply pressing the accelerator pedal. Afterwards, when you release the accelerator pedal, the car will return to the speed saved previously.

### Restoring the speed stored in the memory

If the device has been switched off after braking, the speed saved previously can be restored as follows:

- accelerate gradually until you reach a speed close to the one stored in the memory;
- shift normally until the gear selected when the speed was saved in the memory (4<sup>th</sup>, 5<sup>th</sup> or 6<sup>th</sup> gear)
- press the pushbutton **C (RCL)**.

### Increasing the speed stored in the memory

The speed stored in the memory can be increased in two ways:

- by pressing the accelerator and then saving the new speed reached (turn the ring nut **B** for more than three seconds)

or

- by turning ring nut **B** temporarily to position (+): Each pulse transmitted by the ring nut will originate a slight increase in speed of about 1 mph, whereas constant pressure will cause a continuous increase in speed.

When ring nut **B** is released, the new speed is automatically stored in the memory.

### Reducing a speed saved in the memory

The speed stored in the memory can be reduced in two ways:

- by switching off the device, pressing the brake pedal and then saving the new speed in the memory (turning ring nut **B** to the (+) position for at least three seconds);

or

- by keeping ring nut **B** turned to the (–) position until the new speed is reached: the latter will be stored automatically.

### Resetting the speed stored in the memory

The speed stored in the memory is automatically zero-reset:

- by switching the engine off
- or
- by putting the switch **A** on the OFF position.



When driving with the speed control activated, do not shift to neutral. It is advisable to switch on the cruise control only when traffic and road conditions permit proper use of this device, that is: on straight and dry roads, expressways or highways, smooth-flowing traffic and smooth asphalt. Do not switch this device on in the city or in heavy traffic.



The speed control can only be switched on at speeds exceeding 18 mph (30 km/h).



The device can only be switched on in 4<sup>th</sup>, 5<sup>th</sup> or 6<sup>th</sup> gear, depending upon the car speed.



When driving downhill with the device switched on, the car may pick up speed slightly exceeding the speed stored in the memory due to the change in the engine load.



In the case of faulty operation or failure of the device, move switch **A** to the OFF position and contact your Authorized Maserati Dealer after having checked the fuse.



Switch **A** can be left on the ON position at all times without damaging the device. However case, it is advisable to deactivate the device when it is not in use. Move switch **A** to the OFF position to prevent speeds from being unintentionally saved in the memory.





## Electronic suspension (optional)

The electronic system managing the vehicle suspensions is the result of the sophisticated processing run by the onboard sensors, which are designed to optimize performance. The system is capable of constantly monitoring suspension damping by means of the actuator fitted on each shock absorber. It is possible to adjust the shock absorber setting according to the road and to the vehicle dynamic conditions, improving comfort and road grip.

By pressing button **A**, even when the car is running, the driver can choose a normal or sport setting for the suspensions, depending on his/her own driving style. The system will operate with a "softer" shock absorber setting if the normal mode is chosen, or with a more "rigid" setting if the SPORT mode is selected.

The system is managed by an electronic control unit which controls the solenoid valves on each shock absorber, modifying their damping and therefore their setting.

The sensors which allow the ECU to calculate the car speed, vertical and lateral acceleration, instantaneous pressure in the braking system and thereby to manage the suspension damping are the following:

- vertical acceleration sensor
- LH front vertical acceleration sensor
- RH front vertical acceleration sensor
- Rear vertical acceleration sensor
- LH front wheel acceleration sensor
- RH front wheel acceleration sensor
- drive speed sensor
- brake pedal switch.

The strategy adopted by the system for controlling suspension damping is designed to minimize the vehicle's vertical vibrations (rolling and pitching).

The activation of the SPORT mode with suspension sport setting also affects the ASR system and the "Cambiocorsa" gearbox (when fitted), modifying their setting as well for a sportier drive.

### Self-diagnosis

Each time the engine is started, the system performs a self-diagnosis, which is indicated by the switching on of the warning light  on the multi-function display.

### Setting selection

The driver can select, in relation to roadbed, speed, driving style and comfort, one of the two setting levels provided by the system: normal or "sport".

Normal setting, active when the SPORT function is deactivated, favors comfort and higher driving stability with low and average grip conditions.

"Sport" setting, active when the SPORT function is enabled, favors and permits sportier driving with the improved road holding.

Whenever the car is started, the system will provide the last setting selected before engine switching off.

The "sport" setting can be switched on only with the ignition key in the **MAR** position and it is enabled by pressing the pushbutton **A**, even when the car is moving. when the SPORT mode is activated the **SPORT** warning light on the multi-function display and the button led light up.

**WARNING: The SPORT setting is not advisable when roads are not in excellent condition or are slippery.**

Press pushbutton **A** again to reset the normal setting, even when the car is moving: when the normal setting is activated the **SPORT** warning light on the multi-function display and the button LED go off.

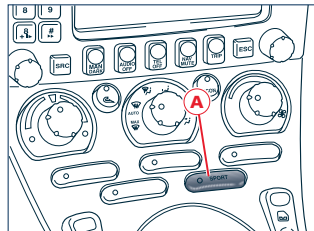

The electronic suspension adjusting system works jointly with the **MSP** system (Yaw prevention monitoring system): when the suspensions are set to normal, stability is increased under medium and low grip conditions, while when the **SPORT** mode is enabled, the **MSP** system optimizes a sport-type driving.

**WARNING Under low grip conditions (when there is ice, snow, sand, etc.) do not enable the SPORT mode, even with the MSP switched on.**







### Fault signals

When driving the car, if one or more of the electrical components in the system is malfunctioning, in addition to switching on of the warning light  on the multi-function display, the electronic control unit checks that the shock absorbers are set to a pre-established calibration, which permits a normal car set-up.

Should the fault involve one shock absorber only, this is no longer controlled by the electronic control unit and remains in the position it had when the fault occurred. It is therefore possible for one of the four shock absorbers to work with a fixed setting, different from that of the other ones.

**WARNING:** In the event of a malfunction in the electronic system controlling the suspensions, which is indicated by the warning light  on the multi-function display switching on while driving the car, you should keep a moderate speed and have the car checked as soon as possible by your **Authorized Maserati Dealer**.

If a problem occurs while driving, indicated by the warning light  on the multi-function display switching on, it is advisable to stop the car when possible and turn the ignition key to the **STOP** position and then restart the engine.

If the problem is no longer present and the warning light  on the multi-function display does not switch on again, the electronic suspension system will resume normal operation.

However, if the problem persists, the warning light  on the multi-function display will switch on again. In both cases, the system must be checked by your **Authorized Maserati Dealer**.

The detected fault is memorized by the electronic control unit and can be diagnosed at your **Authorized Maserati Dealer** even if it has disappeared spontaneously.

## Headlights

### Headlight beam aiming

It is essential that the headlights are adjusted properly, not only for the comfort and safety of the driver but also for all road users. Moreover, correct beam aiming is an essential requirement of local traffic laws.

To ensure that the driver and all other users benefit from the best visibility conditions when travelling with the lights on, the car must feature a correct beam setting.

Consult your **Authorized Maserati Dealer** for a check and any adjustments required.

### Gas-emitting headlights (optional)

The gas-emitting (Xenon) headlights work with an electric arc saturated with Xenon gas under pressure, instead of the incandescent filament. The light produced is markedly superior to that of traditional light bulbs, in terms of quality (brighter light) as well as of the span and positioning of the area illuminated. The advantages offered by better lighting are perceptible (less eye strain and increased orientation for the driver and thus driving safety) especially in the case of bad weather, fog and/or insufficient road indications owing to the broader illumination of the side zones, which are normally left in the dark.

The much broader illumination of the side zones is designed to increase driving safety as it offers the driver better detection of other persons on the side of the road (pedestrians, bicycle riders, and motorcycle drivers).

The electric arc requires very high voltage for striking, but afterwards power is supplied at a lower voltage. The headlights reach maximum brightness about 0.5 seconds after being switched on.

The strong light produced by this type of headlight requires the use of an automatic system to keep the position of the headlights constant and to prevent glare for approaching cars, in the case of braking, acceleration or load transport.

The electromechanical system for automatic retention of the constant position renders the device for headlight angle adjustment unnecessary.

The Xenon headlights are very long-life.



**DANGER - RISK OF ELECTRICAL SHOCKS! If bulb replacement is necessary, contact your local Authorized Maserati Dealer.**





## Driving conditions

### Before your trip

Check the following at regular intervals and always before long trips:

- tire pressure and conditions
- levels of fluids and lubricants
- conditions of the windshield wiper blades
- proper operation of the warning lights and of the external lights.

**WARNING: In any case, it is advisable to carry out these checks at least every 500 mi (800 km), and to always comply with the compulsory measures prescribed by the factory scheduled maintenance plan.**

It is also advisable to:

- clean the glass on the external light and all other glass surfaces
- correctly adjust the mirrors, steering wheel, seats and seat belts.

## Capacities

**WARNING: Use unleaded fuel only! The use of fuel containing lead would irreparably damage the catalytic converters.**

For lubricant and fluid specifications and amounts, follow the instructions listed in the chapter on "CAPACITIES AND TECHNICAL SPECIFICATIONS".

### Safe driving

Although the car is fitted with active and passive safety devices, the driver's conduct is always a decisive factor for road safety.

Below are some simple rules for traveling safely in different conditions. You will be, no doubt, familiar with some of them but, in any case, it would be useful to read them carefully.

## Before you drive

- Ensure that lights and headlights are working properly.
- Carefully adjust the positions of the seat, steering wheel, seat belts and rear-view mirrors to obtain the best driving position.
- Ensure that nothing (mat covers, etc.) is blocking the pedals.
- Carefully arrange any objects in the luggage compartment, to prevent sudden stops from jerking them forward.
- Avoid heavy meals before a trip. A light snack helps to keep your reflexes sharp. In particular, avoid drinking alcohol.
- Remember to check the indications contained in the section "Before your trip", in this chapter, periodically.

 In addition to being prohibited by current regulations, it is extremely dangerous to travel inside the luggage compartment or on the car hood. In the event of an accident, persons transported in this manner are at a much greater risk of serious injury. Passengers must only travel seated in the car seats, with the seat belts properly fastened. Always check that both you and car occupants have their seat belts correctly fastened.

### Travelling

- The first rule for safe driving is caution. Being careful also means being in a position to be able to predict driving behavior of other drivers that is improper or careless.
- Keep a safe distance from vehicles in front of you, adjusting this distance in accordance to the car speed and traffic conditions.
- Strictly follow all traffic regulations and, stay within posted speed limits.
- Long trips should be undertaken in optimal physical condition.

 Driving under the influence of drugs alcohol, or certain medicines is extremely dangerous for the driver and for others.

 Always fasten your seat belts. Traveling without your seat belt fastened increases the risk of serious injury in the event of a collision.

- Do not drive for too many hours at a time. Make frequent stops to stretch your legs and refresh yourself.
- Ensure that the air inside the passenger compartment is changed constantly.
- Never coast downhill with the engine off: the braking action requires greater effort on the pedal due to the absence of the engine brake and of the brake servo.





### Driving at night

The main guidelines to follow when driving at night are set out below:

- Use extra caution: at night, driving conditions are more demanding.
- Reduce your speed, especially on roads with no streetlights.
- At the first signs of drowsiness, stop: to continue driving would be a risk for yourself and for others. Proceed only after you have had proper rest.
- Keep the car at a greater distance from vehicles in front of you than you would use during the day: it is difficult to assess the speed of other vehicles when you can only see their lights.
- Ensure that the headlights are aimed correctly: if they are too low, they reduce visibility and strain the eyes. If they are too high, they may bother the drivers of other cars.
- Use the high beams only outside of densely-populated areas and when you are sure that they will not disturb other drivers.
- When another vehicle is approaching, switch from high beams (if on) to low beams.
- Keep lights and headlights clean.
- Outside of densely-populated areas, beware of animals crossing the road.

### Driving in the rain

Rain and wet roads are dangerous. On a wet road all maneuvers are more difficult since wheel grip on the asphalt is significantly reduced. This means that the braking distances increase considerably and the road holding decreases.

The main guidelines to follow when driving in the rain are set out below:

- Reduce your speed and keep a greater safety distance from the vehicles in front of you. High speed may result in a loss of control and aquaplaning.
- Heavy rain also substantially reduces visibility. In these circumstances, even during the day, turn on the low beams, to be more visible to other drivers.
- Position the air conditioning and heating system controls for the demisting function, in order to avoid any visibility problems.
- Periodically check the conditions of the windshield wiper blades.

### Driving in fog

If the fog is dense avoid traveling where possible.

When driving in mist or fog:

- Keep a moderate speed.
- Even in the daytime, turn on the low beams, and the front and rear fog lights. Do not use the high beams.
- Remember that fog creates dampness on the asphalt and thus any type of maneuver is more difficult and braking distances are extended.
- Keep a greater than normal distance from the vehicle in front of you.
- Avoid sudden changes in speed as much as possible.
- Whenever possible, avoid passing other vehicles.
- If you are forced to stop the car (breakdowns, impossibility of proceeding due to poor visibility, etc.), move the vehicle to the shoulder of if possible. Then turn on the hazard warning lights and if possible, the low beams.
- Sound the car horn rhythmically if you hear another car approaching.

### Driving in the mountains

On downhill roads, use the engine to assist in braking by engaging lower gears so as not to overheat the brakes.

- Never coast downhill with the engine off or in neutral, and never with the ignition key removed.
- Drive at a moderate speed, avoid "cutting" corners.
- Remember that passing other vehicles when driving uphill is slower and thus requires more distance on the road. If you are being overtaken on a hill, slow down and allow the other car to pass.

### Driving on snow or ice

Below are some general advice for driving in snow or ice conditions:

- Keep a very moderate speed.
- Fit the chains (see on page 141-183) or snow tires subject to local laws, (see on page 140-182) when the road is covered with snow.
- Mainly use the engine braking power and avoid sharp braking.
- Avoid sudden acceleration and sharp changes in direction.
- During the winter season, even apparently dry roads can have icy sections. Be careful when crossing bridges, viaducts and roads that have little exposure to the sun and are bordered by trees and rocks. They may be icy.
- Keep a greater than normal distance from the vehicles in front of you.





## Pollution control devices

Even if the car is fitted with anti-pollution devices, the environment deserves the utmost respect from every one of us.

By following a few simple rules, the car driver can help reduce damage to the environment and very often can reduce his fuel consumption as well. In this regard, some useful information is listed here below.

The correct operation of the anti-pollution devices is not only less harmful to the environment, but also affects vehicle efficiency.

So, keeping these devices in good working condition is the first rule for driving both ecologically sound and economically.

The first rule is to follow the factory Scheduled Maintenance Plan carefully. Always use unleaded fuel.

If starting is difficult, do not make prolonged attempts.

For any emergency starting, only use an auxiliary battery.

When driving, if the engine starts running poorly, continue driving, but reduce the engine performance required to a minimum and contact your **Authorized Maserati Dealer** as soon as possible.

Never run the engine, even if only for testing, with one or more spark plugs disconnected.

Do not warm up the engine making it idle before starting off, apart from when the external temperature is very low and, even then, for no longer than 30 seconds.



**During normal operation the catalytic converter develops high temperatures. Do not, therefore, park the car on flammable materials (grass, dry leaves, pine needles, etc.): risk of fire.**

Do not install heat guards and do not remove those already fitted to the catalytic converter and to the exhaust manifold.

Do not spray anything on the catalytic converter, Lambda sensor and exhaust manifold.

In addition to the catalytic and pre-catalytic converters, the vehicles are equipped with a system for controlling fuel vapor emissions. This system, named ORVR, has been designed to help reduce atmospheric pollution by the evaporation from the fuel system. Also, specific to these vehicles is the filler neck which comes equipped with a sealed plug that is grounded to avoid possible sparking during re-fueling. These devices allow the vehicle to be classified in the LEV. 1 homologation category.



**Failure to comply with these rules can originate fire hazards.**



Engine exhaust, some of its constituents, and certain vehicle components contain or emit chemicals known to the State of California to cause cancer and birth defects and reproductive harm. In addition, certain fluids contained in vehicles and certain products of component wear contain or emit chemicals known to the State of California to cause cancer and birth defects or other reproductive harm.

#### Other tips

- Do not warm up the engine with the car stopped: in these conditions the engine heats up much more slowly and increases fuel consumption and emissions. It is much better to move off slowly, avoiding high engine speeds.
  - As soon as traffic conditions and the route permit it, use a higher gear.
  - Avoid pressing the accelerator repeatedly when stopped at traffic lights or before turning off the engine.
  - Keep your speed as even as possible, avoiding unnecessary braking and accelerations, which cause excess fuel consumption and markedly increases exhaust emissions.
- Turn the engine off when stopping for long periods of time.
  - Check tire pressure regularly: if the pressure is too low, fuel consumption increases and the tires are damaged.
  - Do not transport unnecessary objects left in the luggage compartment. The weight of the vehicle affects fuel consumption considerably.
  - Use the car's electrical devices only for the time necessary. The power required increases fuel consumption.





## Parking

Engage the handbrake, engage the 1st gear both uphill and downhill, turn the wheels and switch off the engine (valid for all versions, with either the manual gearbox or the "Cambiocorsa" gearbox).

As 1st gear is the lowest gear, it is suited to use the engine as a brake. When parking on a sharp incline, use a wedge or rock to block the wheels. Never leave the ignition key in the **MAR** position. Always remove the key when getting out of the car.

5



**Never leave children unattended in the car.**



**Do not park the car on paper, grass, dry leaves or other flammable materials. They could catch fire if they come into contact with hot parts of the exhaust system.**



**Do not leave the engine running with the car unattended.**

## Handbrake

The handbrake lever is located between the front seats. To operate the lever, pull it upwards to ensure that the car is secured in position.

**WARNING: If the car is not blocked with the lever between the 3rd and 5th click, contact your Authorized Maserati Dealer to have adjustments made.**

With the handbrake engaged and the ignition key in the **MAR** position, the warning light "PARK" on the instrument panel lights up.

To release the handbrake:

- 1) Slightly lift the lever and press the release button **A**.
- 2) Lower the lever while keeping the button pressed. The warning light "PARK" goes out.

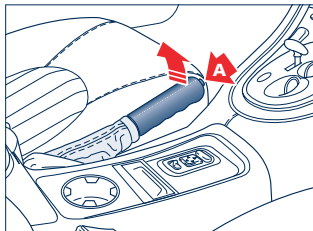



## Tires

### Tire inflation pressure when cold

The tire inflation values, indicated in this manual, are intended for cold tires.



**The maximum speed that can be reached with winter tires is indicated by the tire manufacturer. Always comply with the local regulations.**



**When using the spare wheel (emergency wheel) do not exceed 50 mph (80 km/h). Avoid driving at full throttle, braking sharply and cornering at high speeds.**

### Uniform Tire Quality Grading

All passenger car tires must conform to Federal Safety requirements in addition to these grades.

### DOT Quality Grades

Tires	Tread wear	Traction	Temperature
Michelin Pilot Sport	220	AA	A

#### Treadwear

The treadwear grade is a comparative rating based on the wear rate of the tire when tested under controlled conditions on a specified government test course.

For example, a tire graded 150 would wear one and one-half (1 1/2) times as well on the government course as a tire graded 100.

The relative performance of tires depends upon the actual conditions of their use, however, and may depart significantly from the norm due to variations in driving habits, service practices and differences in road characteristics and climate.

#### Temperature

The temperature grades are "A" (the highest), "B", and "C", representing the tire's resistance to the generation of heat and its ability to dissipate heat when tested under controlled conditions on a specified indoor

#### Traction

The traction grades, from highest to lowest, are "AA", "A", "B", and "C". Those grades represent the tire's ability to stop on wet pavement as measured under controlled conditions on specified government test surfaces of asphalt and concrete.



**The traction grade assigned to this tire is based on straight-ahead braking traction tests, and does not include acceleration, cornering, hydroplaning, or peak traction characteristics**

laboratory test wheel. Sustained high temperature can cause the material of the tire to degenerate and reduce tire life, and excessive temperature can lead to sudden tire failure. The grade "C" corresponds to a level of performance which all passenger car tires must meet under the Federal

Tires



Motor Safety Standard No. 109. Grades "B" and "A" represent higher levels of performance on the laboratory test wheel than the minimum required by law.



**The temperature grade for this tire is established for a tire that is properly inflated and not overloaded. Excessive speed, underinflation, or excessive loading, either separately or in combination, can cause heat buildup and possible tire failure.**

### Winter tires

These tires are specially designed for driving on snow and ice and are fitted to replace the ones supplied with the car.



**Only use winter tires of the prescribed dimensions and brand.**

Your **Authorized Maserati Dealer** is available to provide suggestions as to the types of tires most suited to the use foreseen.

For the type of tires to use, inflation pressures and relative specifications for winter tires, carefully follow the indications found in the "Capacities and Technical Specifications" chapter. The features of these tires are markedly reduced in winter when tread depth is less than 0.16 in (4 mm). In this case, they should be replaced.

The specific features of the winter tires lead to lower performance under normal environmental conditions or on long highway trips, compared to the standard tires.

Therefore, their use should be limited to the performance for which they have been type-approved.



**Fit identical (manufacturer and tread) tires on all four wheels, in order to help ensure safe driving, braking and good maneuverability.**



**Remember that the direction of tire rotation should not be reversed.**

### Snow chains

The use of snow chains is subject to the local state and provincial law.

Use snow chains of reduced dimensions, with a maximum protuberance of 0.35 in. (9mm) beyond the tire tread.

The chains should be fitted only on the driving wheel tires (rear wheels).

Check chain tension after driving for a distance of about 55 yards (50 meters) with the chains fitted.

Deactivation of the MSP system is advised when chains are fitted on the tires.

**WARNING:** Before purchasing or using snow chains or snow tires, we advise you to contact your **Authorized Maserati Dealer** for information.

**WARNING:** Keep a moderate speed, when chains are fitted on the tires. Do not exceed 30 mph (50 km/h). Avoid potholes in the road, do not drive over steps or sidewalks and do not drive on long sections of roads without snow. This will help prevent damage to the car and the road.

---

#### Snow chains: brand/type

Konig/SUPER MAGIC

---

---

#### Rear tire

265/35 ZR18

---







## **In an emergency**

<b>Emergency starting</b>	<b>144</b>
<b>Toolkit</b>	<b>145</b>
<b>If a tire gets a small puncture</b>	<b>146</b>
<b>If an exterior light goes out</b>	<b>152</b>
<b>If an interior light goes out</b>	<b>155</b>
<b>If a fuse blows</b>	<b>158</b>
<b>If the battery is fully discharged</b>	<b>168</b>
<b>If you have to jack up the car</b>	<b>169</b>
<b>If you have to tow the car</b>	<b>170</b>
<b>In the event of an accident</b>	<b>171</b>





## Emergency starting



If the MASERATI CODE does not deactivate the engine immobilizer, the warning light **CODE**  is permanently lit, whereas the warning light **OBDII**  turns off after 4 seconds and then switches on again immediately. In these conditions the engine cannot be started. To start the engine, it is necessary to follow the emergency starting procedure.

**WARNING: We recommend to carefully read the entire procedure before carrying it out. If you make a mistake, you should turn the starter key to STOP and repeat the operations from the beginning (step 1).**

6

1) Read the five-digit electronic code on the CODE CARD.

2) Turn the ignition key to the MAR position: the **CODE**  and **OBDII**  warning lights will remain lit.

3) Press down the accelerator pedal and keep it pressed. After about 8 seconds, the warning light **OBDII**  turns off: you can now release the accelerator pedal and start counting the number of times the warning light **OBDII**  flashes.

4) As soon as the displayed number of flashing is equal to the first digit of your CODE CARD, press down the accelerator pedal and keep it pressed until the warning light **OBDII**  turns off after having remained on for about 4 seconds: then release the accelerator.

The warning light **OBDII**  will start flashing again: as soon as the displayed number of flashing is equal to the second digit of your CODE CARD, press down the accelerator pedal and keep it pressed.

5) Proceed as above for the remaining digits of your CODE CARD.

6) Enter the last digit and keep the accelerator pedal pressed down. The warning light **OBDII**  turns on for 4 seconds and then switches off: you can now release the accelerator.

7) Rapid flashing of the warning light **OBDII**  (for about 4 seconds) confirms that the operation has been completed correctly.

8) Start the engine turning the key from MAR to **AVV**.

If the warning light **OBDII**  remains lit, turn the key to STOP and repeat the procedure from step 1.

**WARNING: After an emergency starting, we recommend to contact your Authorized Maserati Dealer as the emergency procedure must be then carried out each time the vehicle is started until the vehicle is serviced.**

## Toolkit

The car is equipped with the following tools:

- toolkit, located in the luggage compartment
- spare wheel with electric compressor, jack and tools is (optional) located inside the spare wheel itself.

The tools which may be contained in the box fixed to the luggage compartment panel by belt, are:

- universal pliers
- 8 mm open end wrench
- 10 mm open end wrench
- 13 mm open end wrench
- 17 mm open end wrench
- slot screwdriver
- phillips-head screwdriver
- towing hook.

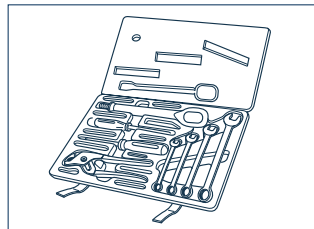



## If a tire gets a small puncture

### Precautions in the event of a small puncture

A tire with a small puncture, it can be temporarily repaired using the special tire inflation kit supplied with the car and housed in the luggage compartment.

The tire inflation kit must always be kept in its special container.

6



If a tire gets a small puncture

146



After using the inflation kit, the car must be however considered to be in an emergency situation: drive slowly (maximum permissible speed 50 mph - 80 Km/h) and with the utmost care, especially when cornering.



Replace the tire as soon as possible: punctured tires should not be repaired, for safety reasons.

**WARNING:** When using the tire inflation kit, always carefully follow the manufacturer's instructions on the bottle itself.

**WARNING:** The tire inflation kit is to be used to temporarily repair only one tire punctured by small-sized sharp objects: the inflation kit cannot repair large holes or tears and cannot repair damages due to running with flat tire.



Keep the tire inflation kit into its container, away from children's reach. Do not inhale or swallow and avoid contacts with skin and eyes.



The inflation kit is under-pressure. Keep away from sun beams and protect it against temperatures exceeding 122 °F (50°C), do not pierce and keep away from open flames, also after use. Do not spray on open flames or parts at high temperature.



The puffing material contained in the tire inflation kit is not suitable for a definitive tire repair. The repaired tire has to be replaced as soon as possible. Inform the service workshop staff that you have repaired the tire using the special puffing material contained in the tire inflation kit.

### Spare wheel (emergency wheel - optional)

 **With the spare wheel fitted, never exceed the maximum speed of 50 mph / 80 Km/h; in fact, exceeding this speed jeopardizes the stability, road holding and braking of the car. Avoid driving at full throttle, braking sharply and cornering at high speeds.**

Upon request, the car can be fitted with an optional spare wheel (emergency wheel), jack and tools for replacing a wheel.

The spare wheel is of a special type and is housed in the luggage compartment. The spare wheel is supplied deflated, for space-saving reasons, with an electric compressor to inflate it.

If a tire is punctured, proceed as follows:

- Stop the car in safe place, where it does not represent a hazard situation for the road traffic and where the wheel can be replaced safely. The car must be parked on a level and firm ground.
- Pull the handbrake.
- Engage the 1st or reverse gear.

- If necessary, turn on the hazard warning lights and position the warning triangle at the prescribed distance.

**WARNING:** In the event of downhill or uneven roads, place wedges or other objects under the wheels, in order to hold the car.

- Remove the spare wheel covering from the luggage compartment panel.

Unscrew knob **A**, remove the cover **B** and take out the spare wheel with the jack, the compressor and the tools for replacing the wheel.

The box located inside the spare wheel contains:

- an electric compressor **C**, including a pressure gauge and the special union for inflating the spare wheel
- a wrench **D** for the wheel studs and for the jack operation
- a bushing **E** to be fitted on the wrench to loosen the wheel studs and to operate the jack
- no. 5 studs **F** for fitting the spare wheel
- a jack **G**.

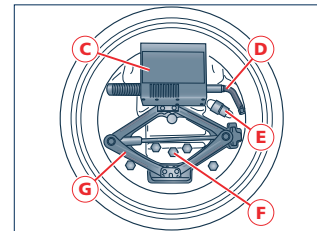
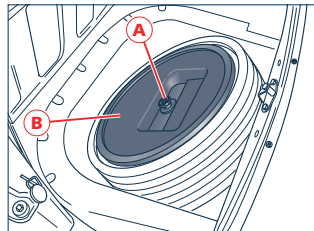

*If a tire gets a small puncture*





- Open the compressor cover and take out the hose with the pressure gauge **H** and the electric wire **L** with the power plug.
- Unscrew the spare wheel's valve cap and screw down the union **M** for the inflating pipe on the valve.
- Open the cap of the power plug **P**, housed in the right hand side of the luggage compartment, and insert the connection **L**.
- Turn the ignition key to **MAR** to supply power to the plug and activate the compressor pressing switch **N**.

- Stop the compressor when the pressure indicated on the pressure gauge **H** is 2.5 bar (250 kPa / 35 psi) and screw the valve cap.

**WARNING:** We recommend to check the tire pressure on the gauge when the compressor is off, in order to have a more precise reading.

**WARNING:** Do not use the compressor for more than 20 minutes: risk of overheating! The compressor has been designed for inflating the spare wheel only; do not use it to inflate mattresses, rubber boats etc.

**WARNING:** Power is supplied to the current plug only when the key is turned to **MAR** and it can only be connected to devices with a power absorption of 15A maximum (180W power). Do not connect devices with a higher power absorption to the current plug. A prolonged power absorption can discharge the battery, preventing the engine from being started once again.

- Fit the bushing **E** onto the wrench **D** and loosen the 5 fastening studs on the wheel to be replaced by about one turn.

6

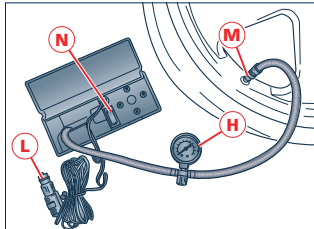

If a tire gets a small puncture

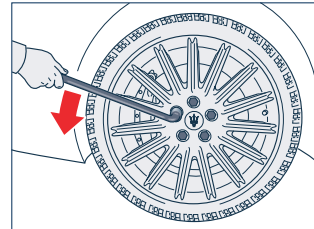
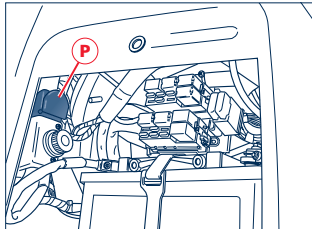

148

- Take out the jack from the box and open it partially.

- Place the jack near the wheel to be replaced, in one of the indicated positions.

- Make sure that the jack head is properly fitted into one of the special seats on the side member.

 Failure to position the jack correctly could result in the car dropping, damage to the body when raised, and personal injury.

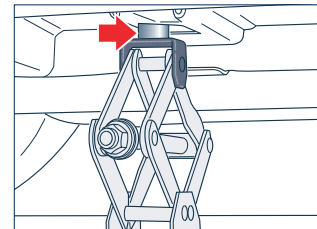
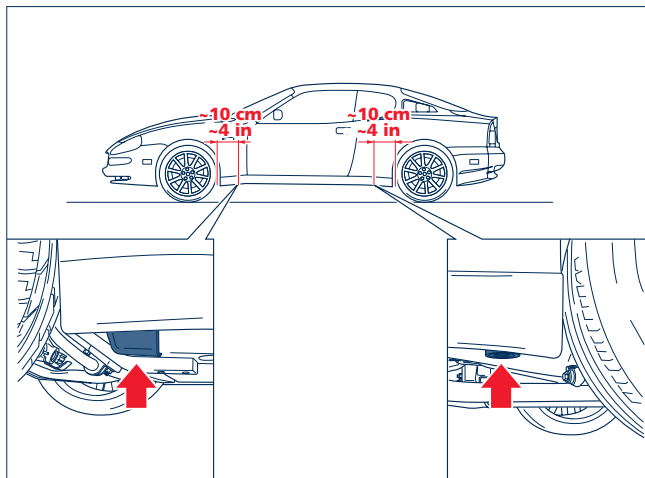





- Insert the wrench onto the jack and rotate it until the wheel rises a few inches off the ground.
  - Loosen the 5 studs completely and remove the wheel.
  - Fit the spare wheel and fix it using the 5 special studs F, found in the box.
  - Screw the 5 new fixing studs.
- Turn the jack wrench to lower the car and withdraw the jack.
  - Fully tighten the studs as shown in the illustration, starting first with one stud and then with the one diagonally opposed and so on.

 **The spare wheel must be fitted using the supplied studs only. Remember to keep the studs from the removed wheel, which must be used when refitting the wheel after repair.**

 **The spare wheel is narrower than the standard ones and must be used only to travel the necessary distance to reach a service station, where the punctured tire can be repaired.**

 **The inflating pressure for the spare wheel must be 2.5 bar (250 kPa / 35 psi).**

 **For safety reasons, it is absolutely forbidden to travel with more than one spare wheel fitted on the vehicle at the same time.**

 **Snow chains cannot be fitted on spare wheels.**

 **The maximum total life of the spare wheel is approx. 1,860 miles / 3,000 km.**

6

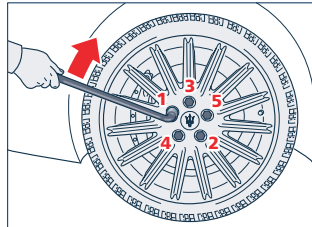
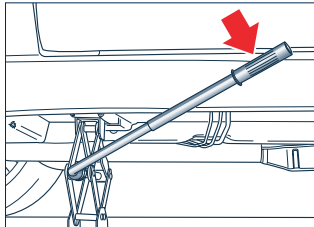

150

*If a tire gets a small puncture*



### Refitting the standard wheel

- Following the procedure described above, lift the car and remove the spare wheel.
- Fit the standard wheel using the tighten studs, removed during the disassembly procedure.
- Tighten the studs using the special wrench.



**The standard wheel must be fitted using the specific studs only. Put back the spare wheel's studs into the box, to use them again in the event of refitting the spare wheel.**

- Lower the car and remove the jack.
- Fully tighten the studs following the sequence indicated before.



**Observe the tightening torque for the wheel studs ( $98 \pm 10$  Nm).**

On completion of the operation:

- Thoroughly deflate the spare wheel, exerting pressure on the valve through the protruding piece of the valve cap.
- Position the jack, the wrench with the bushing and the special studs in their box and put it back into the spare wheel.
- Position the spare wheel in the luggage compartment, close it with its cover and secure it to the panel with the clamping device.
- Cover the spare wheel with the luggage compartment covering panel.



**After refitting the standard wheel, check the tire pressure.**



**The jack can be used only to replace the wheels. Never be use it repairs under the car.**



## If an exterior light goes out

**WARNING:** Before replacing a lamp, make sure that the corresponding fuse is in good working condition. Use only new and original bulbs having the same features as the older ones for replacement.

### Front lights

To access the front lights under the car it is necessary to remove the wheel housing.

It is therefore recommended to contact your **Authorized Maserati Dealer** to replace the bulbs for the low beams, high beams, fog lights, parking lights and direction indicators.



**In case of cars equipped with gas-emitting headlights (Xenon headlights), to check the system and to replace the bulbs if necessary, contact your Authorized Maserati Dealer only: RISK OF ELECTRICAL SHOCKS!**

### Rear lights

The rear light bulbs are arranged as follows:

- A – Parking light bulb (P 21/5W)
- B – Direction indicator light bulb (PY 21W)
- C – Stop light bulb (P 21 W)
- D – Reverse gear light bulb (P 21 W).

To replace a light bulb:

- 1) Lift the luggage compartment lid.
- 2) Open the covering panel on the light.
- 3) Rotate the bulb holder F in a counter clockwise direction and slide it out.
- 4) Remove the bulb G gently pushing it and rotating it in counter-clockwise direction.
- 5) Insert the new bulb by slightly pushing it and rotating it in a clockwise direction.
- 6) Insert the bulb holder and rotate it in a clockwise direction.
- 7) Close the covering panel.

6

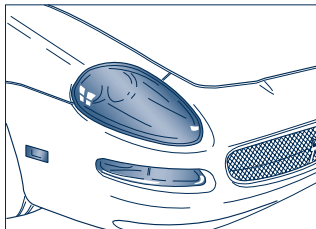

If an exterior light goes out

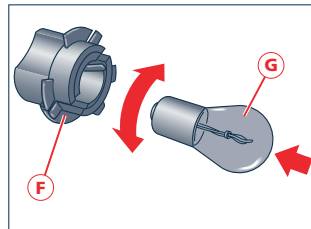
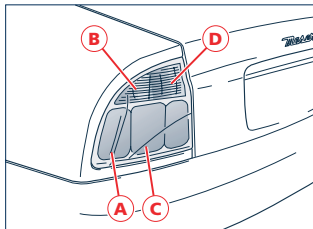

152

### Directional indicator lights

To replace the direction indicator light bulb (5W):

1) Push forward the directional indicator to press on the spring clip H.

2) Remove the rear part releasing the retaining tab L and remove the unit.

3) Remove the bulb holder M turning it in a counter direction.

4) Remove and replace the bulb.

5) Refit the bulb holder turning it in a clockwise direction.

6) Refit the direction indicator inserting first the retaining tab on the rear part and then pressing the front part until hearing the spring clip click into position.

**WARNING:** Proceed with care when removing the side directional indicator light to avoid damages to the car body or to the indicator itself.

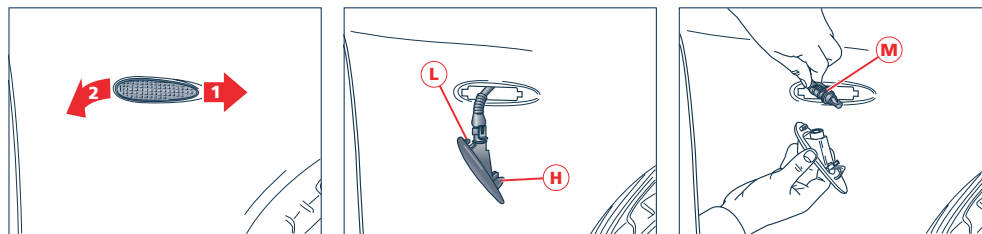



### Side marker lamp

To replace the side marker lamps, we recommended to contact your **Authorized Maserati Dealer**.

### Third stop light

In order to replace the bulbs, the lens unit has to be removed. It is therefore recommended that you contact your **Authorized Maserati Dealer**.

### License plate lights

To replace the license plate light bulb:

- 1) Loosen the fastening screws for the lens/bulb holder unit.
- 2) Remove the unit and replace the bulb.

6

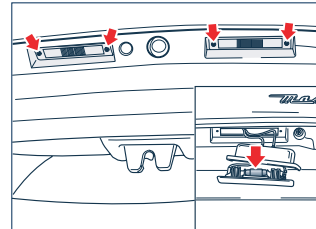
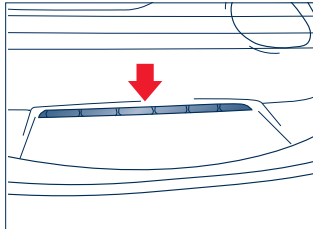
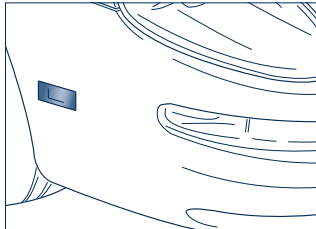

154

*If an exterior light goes out*

## If an interior light goes out

**WARNING:** Before replacing a lamp, make sure that the corresponding fuse is in good working condition. Use only new and original bulbs having the same features as the older ones for replacement.

### Front overhead lights

To replace the bulbs:

- 1) Remove the overhead light by gently levering it out with a flat head screwdriver at point **A**.
- 2) Replace the bulb concerned:
  - timed light **B** (12V – 10W torpedo)
  - reading light **C** (12V – 3W).

3) Refit the overhead light inserting the left-hand side first and then pushing the right-hand side into place.

**WARNING:** When refitting the overhead light, make sure that the electric wires are correctly arranged and do not interfere with the edges of the overhead lights or its retaining tongues

### Rear overhead lights

To replace the bulb (12V – 5W torpedo):

- 1) Remove the ceiling light by gently levering it out with a flat head screwdriver at point **D**.
- 2) Replace the bulb.
- 3) Refit the ceiling light inserting the connector side first and then pressing on the other side until it fits into place.

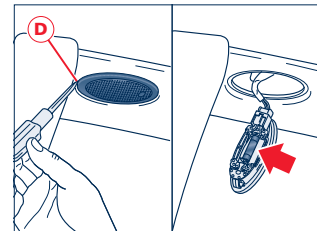
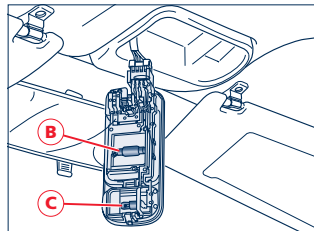
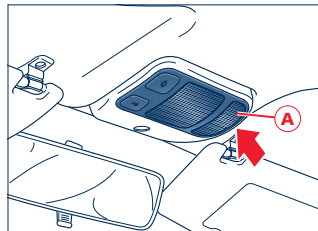

*If an interior light goes out*





### Vanity mirror light

To replace the bulb (12V – 5W torpedo):

- 1) Remove the fixing plate by levering it out at points E.
- 2) Replace the bulb.
- 3) Refit the fixing plate by pressing it into place.

### Glove compartment light

To replace the bulb (12V - 5W "torpedo" type):

- 1) Remove the lens by levering it out gently in point F with a flat head screwdriver.
- 2) Replace the bulb.
- 3) Refit the lens, inserting first the two-tab side and then pressing on the other side.

### Courtesy lights (below door)

To replace the bulb (12V - 5W all glass):

- 1) Lever it out gently from its ceiling light seat G with a flat head screwdriver and remove it.
- 2) Press the sides of lens H to release the retaining tabs and remove the lens.
- 3) Replace the pressure-fitted bulb.
- 4) Refit the lens.
- 5) Refit the lighting unit inserting first the electrical connector side and then pressing on the other side to hook up the clip.

6

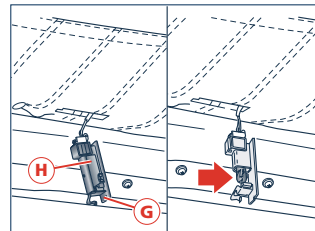
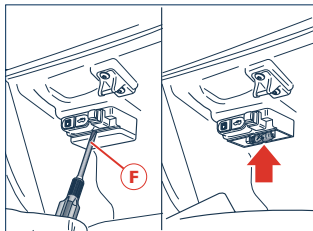
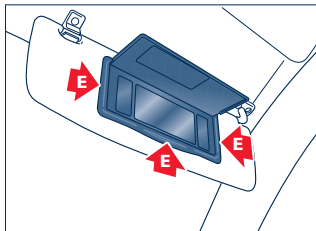

156

*If an interior light goes out*

### Luggage compartment light

To replace the bulb (12V - 5W all glass):

- 1) Lever it out gently from its ceiling light seat L with a flat head screwdriver and remove it.
- 2) Press the sides of lens M to release the retaining tabs and remove the lens.
- 3) Replace the pressure-fitted bulb.
- 4) Refit the lens.
- 5) Refit the lighting unit inserting first the left side and then pressing on the right side to hook up the clip N.

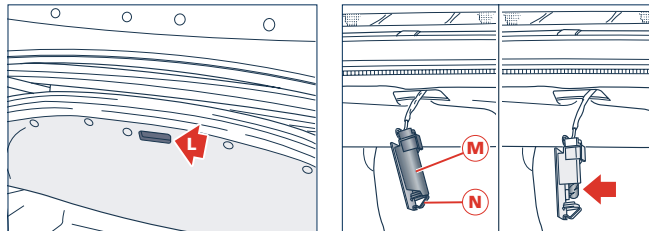

*If an interior light goes out*





## If a fuse blows

### Replacing the fuses

When an electrical device ceases to work, check that the corresponding fuse is sound.

A - Sound fuse.

B - Blown fuse.

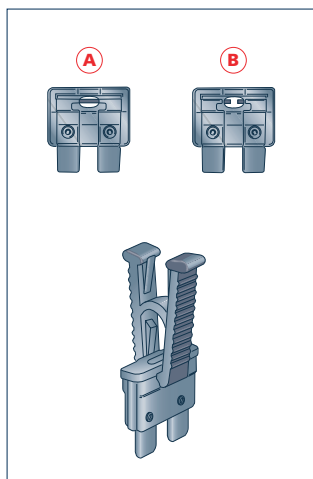

6

158

*If a fuse blows*

Replace the faulty fuse with a new one featuring the same rating (same color). If the fault reoccurs, consult your **Authorized Maserati Dealer**.



**Never replace a blown fuse with anything other than a sound fuse (same rating/color).**

### Position of fuses/relays

The fuses/relays are located in various parts of the car, namely:

- Under the dashboard on the right hand side.
- In the engine compartment.
- In the right hand side of the luggage compartment.

### Fuse Color

	ocher yellow	brown	red	pale blue	yellow	white	green
Amps	A5	A7.5	A10	A15	A20	A25	A30

### Maxi Fuse Colors

	yellow	green	orange	red	blue
Amps	A20	A30	A40	A50	A60





### Relays under the dashboard

Posit.	Type	Function
A	Micro 20A	Driver's seat heating
B	Micro 20A	Passenger's seat heating
C	Micro 30A	Connected devices cut out during ignition
D	Micro 30A	Connected devices not cut out during ignition
E	Micro 20A	Electronic injection main relay
F	Micro 20A	Maserati CODE System
G	Micro 20A	Air conditioner compressor
H	Micro 20A	Horns
I	Micro 20A	High beams
L	-	Not used
M	Micro 30A	Starter motor
N	Micro 20A	Low beams

### 6

### Fuses under the dashboard

Posit.	Amps.	Color	System/Component
1	30A	Green	+30 driver's seat
2	30A	Green	+30 Passenger's seat
3	7.5A	Brown	Passenger's seat heating
4	7.5A	Brown	Driver's seat heating
5	30A	Green	Air conditioning and ventilation unit
6	30A	Green	Headlight washer timer
7	10A	Red	+87 main relay

160

*If a fuse blows*



Posit.	Amps.	Color	System/Component
8	15A	Pale blue	+87 main relay for Lambda sensor, air flow meter etc.
9	15A	Pale blue	+87 main relay for injectors, coils
10	7.5A	Brown	Air conditioner compressor
11	10A	Red	+15 ABS from electronic injection main relay
12	15A	Pale blue	Horns
13	–	–	Not used
14	10A	Red	RH high beam
15	15A	Pale blue	LH low beam and headlight aiming adjuster
16	10A	Red	LH high beam, high beam warning light
17	15A	Pale blue	RH low beam, headlight washer enable, manual headlight aiming adjuster
18	30A	Green	Starter motor
19	–	–	Not used
20	–	–	Not used
21	20A	Yellow	Directional lights intermittance
22	7.5A	Brown	Maserati CODE system, CAN line interface, navigator cable bundle instrument (+15 not cut out during ignition)
23	–	–	Not used
24	10A	Red	Stop, clutch
25	7.5A	Brown	ECU for CAN line interface, OBD, Maserati CODE system, multifunction display
26	5A	Ochre yellow	BOGE system (+15 connected devices not cut out during ignition)
27	–	–	Not used
28	5A	Ochre yellow	IGE ECU, ceiling light timer, light switch (+15 connected devices not cut out during ignition)

*If a fuse blows*



Posit.	Amps.	Color	System/Component
29	10A	Red	Ceiling lights, ceiling light timer, (electricals,) seats , luggage compartment and fuel flap opening controls
30	10A	Red	Airbag (+15 connected devices not cut out during ignition)
31	10A	Red	Navigator, clock, tunnel display
32	10A	Red	+15 light switch, Cruise Control, headlight aiming ECU (+15 cut out during ignition)
33	5A	Ochre yellow	Alarm system, preset for satellite alarm
34	10A	Red	+15 electronic injection
35	15A	Pale blue	+30 IGE ECU
36	15A	Pale blue	+30 IGE ECU
37	25A	White	Windshield wiper, windshield wiper washing pumps, wiper (+15 cut out during ignition)
38	15A	Pale blue	+30 ignition switch
39	15A	Pale blue	Radio, navigator
40	20A	Yellow	Centralized lock
41	15A	Pale blue	Cigarette lighter, radio, engine indic., rear view mirrors, ceiling light, glove compartment lamp (+15 cut out during ignition)
42	30A	Green	Electronic injection main relay
43	30A	Green	Passenger side power window
44	30A	Green	Driver side power windows
45	5A	Ochre yellow	Air conditioning and ventilation system, navigator cable bundle, (+15 connected devices cut out during ignition)
46	7.5A	Brown	+30 electronic injection



### Fuses/relays in the engine compartment

The fuses/relays in the engine compartment, are located on the right-hand side and on the rear panel, right-hand side.

To gain access to the side relays, remove the right-hand covering E of the engine compartment, loosening, then lift the cover F releasing it from the retaining tab.

If necessary, the cover can be removed by pulling it upwards. To refit the engine compartment covering, position it correctly, then press it and rotate the fastening studs.

### Side relay

Posit.	Type	Function
A	Mini 50A	Electronic cooling fan (second speed)
B	Mini 50A	Electronic cooling fan (first speed)
C	Mini 50A	Air pump
D	Timer	Headlight washer with timer

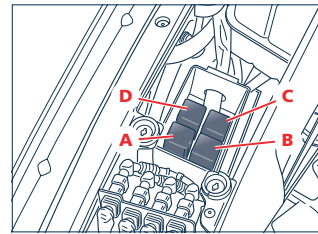
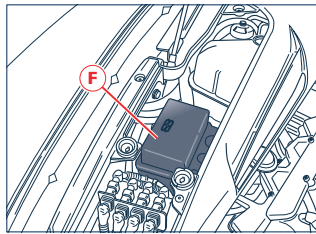
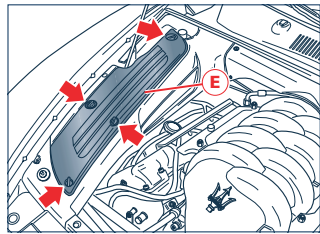

If a fuse blows



To gain access to the fuses on the engine compartment rear panel, remove the rear covering, backing off the fastening screws.

**WARNING:** This work should be performed by your **Authorized Maserati Dealer**.

To access the fuses, remove cover **G** gently levering up the fastening tabs **H**.

### Fuses on the rear panel

Posit.	Amp.	Color	System/Component
1	Maxi 60A	Blue	Air pump
2	Maxi 60A	Blue	ABS
3	Maxi 40A	Orange	First speed fans
4	Maxi 50A	Red	Second speed fans

6

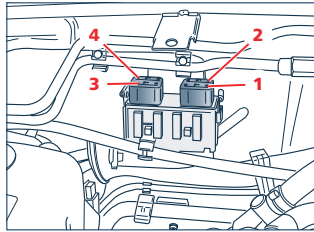
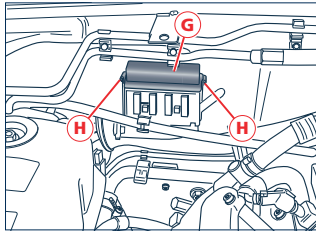

164

*If a fuse blows*



### Relay/fuse box units in the luggage compartment

To gain access to the fuses/relays, open the covering panel **L**, fixed with a Velcro strap on the right-hand side of the luggage compartment.

There are three fuse and relay box units which are located as follows:

- M** - over the battery, in the front side area
- N** - over the battery, in the front side area
- O** - over the battery, in the back side area
- P** - over the battery, in the front side area

To gain access to the fuses and relays of units **M** and **N**, remove the covers by opening the fastening clips.

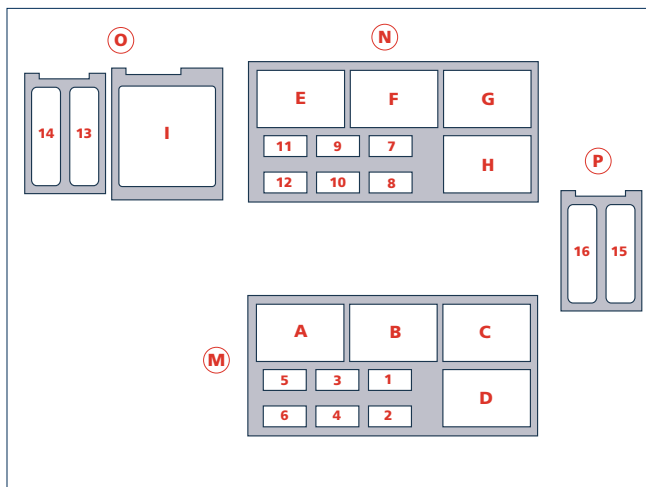
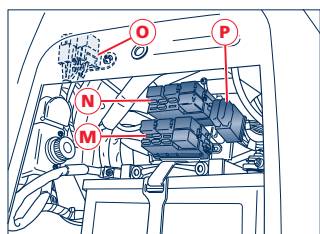
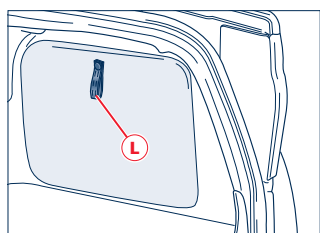

*If a fuse blows*



### Luggage compartment relays

Posit.	Type	Function
A	Micro 30A	Luggage compartment lid opening alarm
B	Micro 30A	Rear Defroster
C	Micro	Fuel pump (first speed)
D	Micro	Fuel pump (second speed)
E	Micro	Luggage compartment lid and fuel tank flap relay cut out
F	Micro 20A	Reverse gear
G	Micro 30A	Fuel tank flap
H	Micro 30A	Luggage compartment lid
I	Mini	"Cambiocorsa" electronically controlled gearbox



### Luggage compartment fuses

Posit.	Amp.	Color	System/Component
1	–	–	Not used
2	20A	Yellow	Fuel pump (rear)
3	7.5A	Brown	Heated rear window and mirror defrosting (rear)
4	30A	Green	Defroster
5	–	–	Not used
6	30A	Green	Radio amplifier
7	30A	Green	Fuel tank flap (rear)
8	–	–	Not used
9	25A	White	Luggage compartment lid, coil for luggage compartment and fuel tank flap opening cut out relay (rear)
10	15A	Pale blue	Power socket
11	7.5A	Brown	Reverse gear, parking sensors, CAN line interface, mirror memory, electronic mirror (rear)
12	–	–	Not used
13	Maxi 20A	Yellow	ECU for “Cambiocorsa” electronically controlled gearbox
14	Maxi 30A	Green	Pump for “Cambiocorsa” electronically controlled gearbox
15	Maxi 40A	Orange	Relay and fuse control units
16	Maxi 50A	Red	Relay and fuse control units



## If the battery is fully discharged

First of all, you are advised to carefully read the Chapter "Maintenance", where a specific section illustrates the precautions to take to prevent the battery from discharging and to help ensure long life.

**WARNING:** Before disconnecting the battery, lower the side windows by at least 1.5-2 in (4-5 centimeters), in order to avoid damaging the strips when opening and closing the doors. When the battery is connected and loaded, this operation is carried out automatically upon opening and closing the door. The windows must remain lowered until the battery is connected once again. If the battery runs flat when the windows are fully raised, open the door only if necessary and taking utmost care. Do not close the door if the window cannot be lowered.

6

168

*If the battery is fully discharged*

### Starting with the auxiliary battery

See the section "Starting the engine" contained in the chapter "Using the Vehicle".

**WARNING:** Under no circumstances should a battery charger be used for an emergency start-up: This could damage the electronic systems, particularly the control units managing the ignition and fuel supply functions.

### Recharging the battery

You are advised to recharge the battery slowly and at a low amperage for about 24 hours.

Follow the below instructions:

- 1) Deactivate the electronic alarm using the radio control.
- 2) Open the trunk and disconnect the terminals of the electrical system from the battery terminals.

**WARNING:** First disconnect the negative pole terminal (-) then the positive pole one (+).

3) Connect the recharger wires to the battery terminals.

4) Switch on the recharger.

5) When the battery is recharged, turn off the recharger before disconnecting it from the battery.

6) Reconnect the terminals to the battery poles, observing the polarity.

**WARNING:** First reconnect the positive pole terminal (+) then the negative pole one (-).

7) Check that the seats work correctly: if not, carry out the "initialization" procedures described in the section "Seats", contained in the chapter "Before you drive".



The fluid contained in the battery is poisonous and corrosive. Avoid contact with the skin and eyes. The battery recharging procedure must be carried out in a ventilated environment away from open flames or possible sources of sparks: risk of explosion and fire.



Battery posts, terminals and related accessories contain lead and lead compounds. Wash your hands after handling.

## If you have to jack up the car



The jack can be used only to replace the wheels. Under no circumstance should it be used for repairs under the car.

### Using the jack

See the section "If a tire gets a puncture", in this chapter (pg. 146)

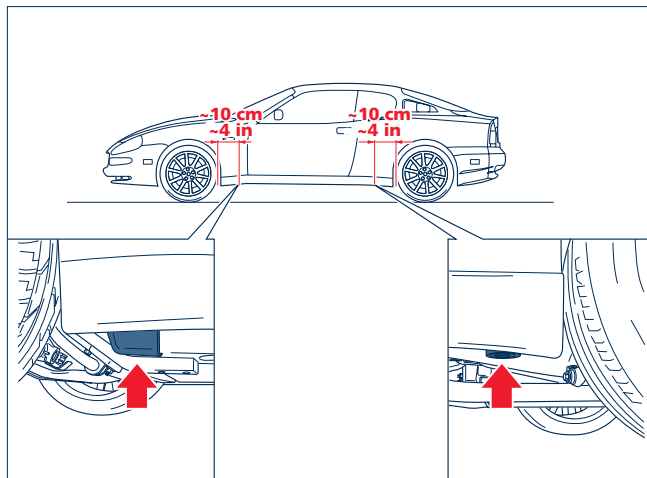

*If you have to jack up the car*





## If you have to tow the car

The car is fitted with a front emergency towing hook. The towing hook is located in the tool box. Do not use other attachment points for towing. To access the towing hook seat, remove the cap on the lower right-hand side of the front bumpers. Screw down the hook into its seat.

**WARNING:** If you have to tow the vehicle with 2 wheels raised, make sure the ignition key is in the **STOP** position. differently, with the **MSP** system activated, the relevant control unit would store a malfunction causing the indicator **MSR** to come up on the multifunction display. This requires the intervention of your **Authorized Maserati Dealer** to have the system restored.



When towing the car, make sure that you observe the road traffic regulations concerning both the towing device and driving conduct.



Before starting to tow, rotate the ignition key to the **MAR** position and subsequently to **STOP** without removing it! Removing the key automatically locks the steering wheel, thereby making it impossible to steer the wheels. Position the gearshift lever in neutral ("N" position for cars with "Cambiocorsa" gearbox).



When towing the car with the engine off, remember that without the assistance of the brake servo, a stronger effort will be required on the brake pedal and on the steering wheel for steering.



Screw down the hook into its seat (approx. 11 turns). Clean the threaded seat before tightening the hook.

6

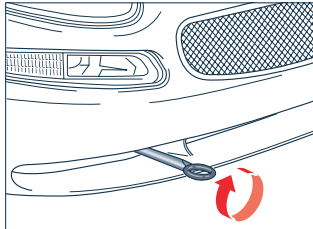
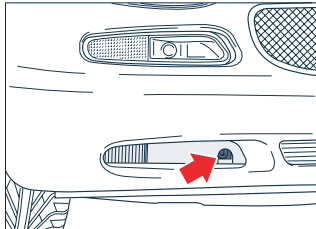

170

If you have to tow the car

## In the event of an accident

It is important always to stay calm.

- If you are not directly involved, stop at a distance of at least ten yards or meters away from the accident area.
- If you are on a highway, stop without obstructing the emergency lane.
- Turn off the engine and switch on the hazard warning lights.
- At night, illuminate the accident area with the headlights.
- Always act with caution: do not risk someone crashing into you.
- Indicate that an accident has occurred by placing the emergency triangle in a well visible position and at the prescribed distance.
- Call the police or other emergency services, providing as much information as possible.
- Remove the ignition key from the vehicles involved.
- If you smell fuel or other chemical products, do not smoke and ask people around you to extinguish their cigarettes.

To extinguish fires, even small ones, use a fire extinguisher, blankets, sand or earth. Never use water.

In accidents on highways, particularly where visibility is poor, there is a high risk of being involved in other collisions. Leave your vehicle immediately and move away from it.

### If there are injured persons

- Never leave an injured person alone.
- Do not crowd around injured persons.
- Reassure the injured person that assistance is on the way and stay close to him/her to help with possible fear.
- Release or cut the seat belts restraining the injured persons.
- Do not give the injured persons anything to drink.
- The injured person should never be moved.
- Remove the injured person from the vehicle only if absolutely necessary. When removing an injured person, do not pull his/her limbs, his/her head and keep the body in a horizontal position.





## Capacities and Technical Specifications

Fuel	174
Engine oil	174
Capacities: quantities and specifications of the products to be used	175
Fuel consumption	177
Technical specifications	178
Tire pressure	185





## Fuel

Only use unleaded premium fuel with high octane number (R.O.N.) - no less than 93.

Tank capacity: about 22 US gallons (84 liters), including a reserve of about 5 US gallons (18 liters).

**WARNING:** The anti-pollution devices of the car require unleaded gasoline to be used at all times. Under no circumstance, not even in emergency situations, should leaded gasoline or gasoline containing benzene be supplied to the fuel tank as you would damage the catalytic converter beyond repair.

**WARNING:** An inefficient catalytic converter results in noxious exhaust emissions which are harmful for the environment.

7

## Engine oil

To check level, please consult the chapter "Maintenance". Do not top up with, otherwise or use oil having characteristics other than those of the oil already used. The gap between the MIN and MAX reference marks on the dipstick corresponds to about 1 liter of oil. Use SAE 5W/40 API SG/CD - CCMC G5 oil for gasoline-powered engines.



## Capacities: quantities and specifications of the products to be used

### Recommended quantities and products

Parts to be refilled	Quantity	Product specifications
Fuel tank (reserve included)	about 22 US gallons (84 liters)	Premium unleaded fuel, no less than 93 R.O.N.
Fuel reserve	about 5 US gallons (18 liters)	
Engine oil:		Multi-grade semi-synthetic or fully synthetic lubricants with SAE 5W/40 strength, over API SG - CD - CCMC - G5 standards. Recommended AGIP TECSINT SL 5W/40.
- scheduled replacement	2.06 US gallons (7.8 liters)	
- top up from MIN to MAX level	0.26 US gallons (1 liter)	<b>WARNING: Do not top up using oil with features other than those of the oil already contained in the engine.</b>
- oil consumption (according to use conditions)	0.13 US gallons/600 mi (0.5 liters/1.000 km)	<b>WARNING: The engine oil consumption depends on the driving style and on the car use conditions.</b>
Windshield/headlight washer fluid reservoir	1.72 US gallons (6.5 liters)	Water and detergent fluid mixture, in the percentage indicated on the product box. Detergent fluid: alcohols and tensio-actives CUNA NC 956-II. Recommended type DP1 <b>WARNING: In the event of temperatures below -4 °F (-20 °C), use pure detergent only.</b>
Cooling system	3.04 US gallons 11.5 liters	Water and coolant fluid mixture, in the percentage indicated on the product box. Coolant: protective with anti-freeze action, inhibited mono-ethylene glycol based, CUNA NC 956-16. Recommended AGIP ANTIFREEZE PLUS ECOPERMANENT.

Capacities: quantities and specifications of the products to be used



Parts to be refilled	Quantity	Product specifications
Battery	74 Ah 700 AMPS	Cold cranking start
Hydraulic servo steering	0.26 US gallons 1 liter	Oil type ATF DEXRON II D LEV, SAE 10W. Recommended AGIP ATF II D.
Manual and "Cambiocorsa" gearbox	0.74 US gallons 2.8 liters	75W/90 over the API GL4-GL5C API MT1-PG2 standards Recommended ROTRA LSX.
"Cambiocorsa" system	0.26 US gallons 1 liter	Oil type CHF Recommended AGIP CHF.
Brake system circuit and clutch hydraulic control	0.29 US gallons 1.1 liters	Synthetic fluid NHTSA n.116 DOT4, ISO 4925, SAE J1703 – J1704, CUNA NC 956-01 Recommended AGIP BRAKE FLUID DOT 4 PLUS.
Air conditioning system coolant	1,100 g	R134a
Air conditioning and ventilation system compressor oil	135 cc	Type SP 10 (Sanden)

**MASERATI recommends to use AGIP products complying with the above mentioned specifications.**

## Fuel consumption

The fuel consumption values shown in the following table were established based on homologation tests.

### Fuel consumption

	Urban	Extra-urban
Manual gearbox	12.4 mpg	21.3 mpg
"Cambiocorsa" gearbox	12.55 mpg	21.3 mpg

**WARNING:** The type of route, traffic conditions, weather conditions, driving style, general condition of the vehicle, set-up/equipment/accessories in the car, use of the air conditioning system, car load, roof rack and other items or situations which may negatively affect the car aerodynamics or wind resistance lead to consumption ratios differing from the reported ones.





## Technical specifications

### Engine

#### General

Type code	M138
Cylinder number and position	8 - 90° V
Number of valves per cylinder	4
Piston bore and stroke	mm 92 x 79.8
Total displacement	cm <sup>3</sup> 4,244
Compression ratio	11.11±0.2 : 1
Maximum output (EEC)	kW 287 HP 390
corresponding rpm	
– manual gearbox	r.p.m. 7,000
– "Cambiocorsa" gearbox	r.p.m. 7,000
Maximum torque (EEC)	Nm 451 kgm 45.9
corresponding rpm	r.p.m. 4,500

### Injection – Ignition

The ignition - injection system is controlled by a single microprocessor electronic control unit (ECU). Engine performance and fuel consumption are both optimized, the former due an improved car drivability and the latter to a better engine operation with partial loads.

#### Injection

– Bosch ME7.1.1 type

#### Ignition

- Static ignition
- Firing sequence: 1-8-6-2-7-3-4-5
- Bosch ignition coil
- NGK PMR8A spark plugs.



### Lubrication system

The engine lubrication system is of the dry sump type with scavenge and delivery pumps aligned with the cooling pump, in a single unit driven by the crankshaft through a chain.

### Cooling system

The engine is cooled by means of an anti-freeze mixture which circulates inside a specific line system equipped with a radiator, a centrifugal pump and an expansion tank.

### Transmission

#### Clutch

Dry double-plate clutch with servo-assisted hydraulic control.

### Manual gearbox and "Cambicorsa" gearbox

Six forward speeds and one reverse.

Gear	Ratios	Total reduction ratios (engine revolutions/wheel revolutions)
1 <sup>st</sup> speed	46/14 = 3.286	12.247
2 <sup>nd</sup> speed	41/19 = 2.158	8.043
3 <sup>rd</sup> speed	37/23 = 1.609	5.997
4 <sup>th</sup> speed	33/26 = 1.269	4.730
5 <sup>th</sup> speed	30/29 = 1.034	3.854
6 <sup>th</sup> speed	28/33 = 0.848	3.160
Reverse	41/16 = 2.563	9.552

#### "Cambicorsa" gearbox

The electronic gearbox technology, which was originally designed for Formula 1 racing, has become today a standard production component. The "Cambicorsa" is a "hydraulic servo" system for the gearbox and the clutch, which however features all the advantages of the dry clutch and mechanical gearbox (reduced weights, strength and reliability, low consumption levels). At the same time, it is more user-friendly, reduces strain from driving in the city traffic or when a frequent gearshifting is required.

Furthermore, it provides excellent performance, soft gearshifting and progressive torque on the wheels. Thanks to the hydraulic servo and to the interface with the engine controller (ECU) as well as with the drive control devices (ASR/MSR), the system is capable of performing "sport" or "comfort" gearshifting, depending on the driver's needs and driving style. The clutch pedal is not fitted in the passenger compartment; the gearshift lever is replaced by electric controls (Up-Down) on the steering wheel, just like on Formula 1 autos.

Technical specifications



The "Cambiocorsa" gearbox helps relieve the driver from bothering and straining aspects of manual transmission management, without depriving him of the pleasure of controlling gearshifting directly. In the event that the driver, in particular situations, prefers to give up this option as well, the total automatic mode can be also enabled.

The servo assisted system basically consists of a hydraulic actuator, fitted directly onto the gearbox housing, which manages both the gear selection and engagement by means of two different pistons.

The two pistons are controlled by a series of solenoid valves, hydraulically powered by an electric pump and a storage battery.

An electronic control unit, after receiving the requests from the driver and after evaluation of the vehicle operation conditions, detected through a series of sensors, autonomously manages gearshifting, thereby controlling clutch, gearbox and engine torque directly.

When shifting gears, the engine control is assisted by the gearbox control.

Interfacing between gearbox and engine control remarkably improves the system performance and relieves the driver, during gearshifting, from any need to synchronize the clutch-accelerator operations. Actually, the accelerator pedal can be even kept pressed down.

The "Cambiocorsa" gearbox not only manages the transmission upon the driver's request, but also "tutors" and assists him while driving.

As a matter of fact, the system is designed to automatically exclude all wrong gearshifting requests. As far as driving assistance is concerned, it furthermore ensures that the first speed is immediately available when the vehicle is stopped and that gears are automatically downshifted in case of sudden deceleration, with subsequent sharp request for acceleration. These aspects help improve driving safety, since the possibilities for the driver to carry out wrong maneuvers are decreased. A display on the instrument panel indicates the gear currently engaged, while diagnostics messages are managed by the electronic control unit through a warning light and a buzzer.

### **Differential**

The ratios are:

#### **Differential reduction torque**

Manual gearbox and "Cambiocorsa" gearbox	$41/11 = 3.727$
--	-----------------

### **Brakes**

#### **Service and emergency brakes**

Disc-type, on four wheels, self-ventilating.  
Two diagonally opposed and independent hydraulic control circuits.  
Vacuum brake servo.  
4-channel ABS system with Electronic Brake force Distribution (EBD).

#### **Handbrake**

Mechanical type, on the rear wheels, operated through the central lever.

### **Suspension**

#### **Front and rear**

Articulated quadrilateral.

#### **Adjustable damping suspension (optional)**

This system allows the driver to choose two settings for the shock absorbers, depending upon the roadbed conditions, speed and comfort.





### Steering

Rack and pinion hydraulic steering, with pump driven by the drive shaft and reservoir. Articulated steering column, with energy absorption and adjustable inclination and height.

- Steering diameter = 39 ft (12 m)
- No. of steering wheel turns = 1,5 (to the left and to the right).

### Wheels

#### Rims and tires

	Rim size	Tire size	Brand tires
front	8"J x 18"	235/40 ZR18	MICHELIN PILOT SPORT TL PIRELLI P ZERO
rear	9.5"J x 18"	265/35 ZR18	MICHELIN PILOT SPORT TL PIRELLI P ZERO
*front	8"J x 18"	225/40 R18	MICHELIN PILOT ALPIN ASYMMETRIC PIRELLI WINTER 210
*rear	9.5"J x 18"	265/35 R18	MICHELIN PILOT ALPIN ASYMMETRIC PIRELLI WINTER 210

\* Winter tires



**The maximum speed that can be reached with winter tires is indicated by the tire manufacturer. In any case, always comply with local regulations in force.**

**Only use winter tires of the prescribed dimensions and brand.**

**WARNING:** Notwithstanding the prescribed sizes, it is essential that tires of the same brand and type are fitted to all the wheels in order to ensure safe driving.

**WARNING:** Do not use air chambers on Tubeless tires.

#### Spare wheel (emergency wheel - optional)

Alloy rim.

Tire size	Brand tire
185/60-17 93P	VREDESTEIN



### Snow chains

Maximum radial protuberance permitted over the tire profile: 0.35 in (9 mm).

Rear tire	Snow chains: brand/type
265/35 ZR18	Konig/SUPER MAGIC

**WARNING:** Snow chains must be fitted only on the rear wheels. Use is subject to local laws Contact your **Athorized Maserati Dealer** for purchasing your snow chains.

### Performance

Maximum speed	km/h	mph
Manual gearbox	283	176
"Cambiocorsa" gearbox	283	176



The maximum speed that can be reached with winter tires is indicated by the tire manufacturer. In any case, always comply with local regulations.

Accelerations at standing start (in seconds)	0-100 km/h 0-62 mph	400 m 437 yd	1,000 m 1,094 yd
Manual gearbox	5.0	13.3	23.9
"Cambiocorsa" gearbox	5.0	13.3	23.9

### Weights

Weights	Manual gearbox	"Cambiocorsa" gearbox
Unladen car weight	3,726 lb	3,792 lb
(with fluids, fuel, tools and accessories)	1,690 kg	1,720 kg
Full load weight (4 occupants and 60 lb (28 kg) in the luggage compartment)	4,387 lb	4,453 lb
	1,990 kg	2,020 kg



## Dimensions

7

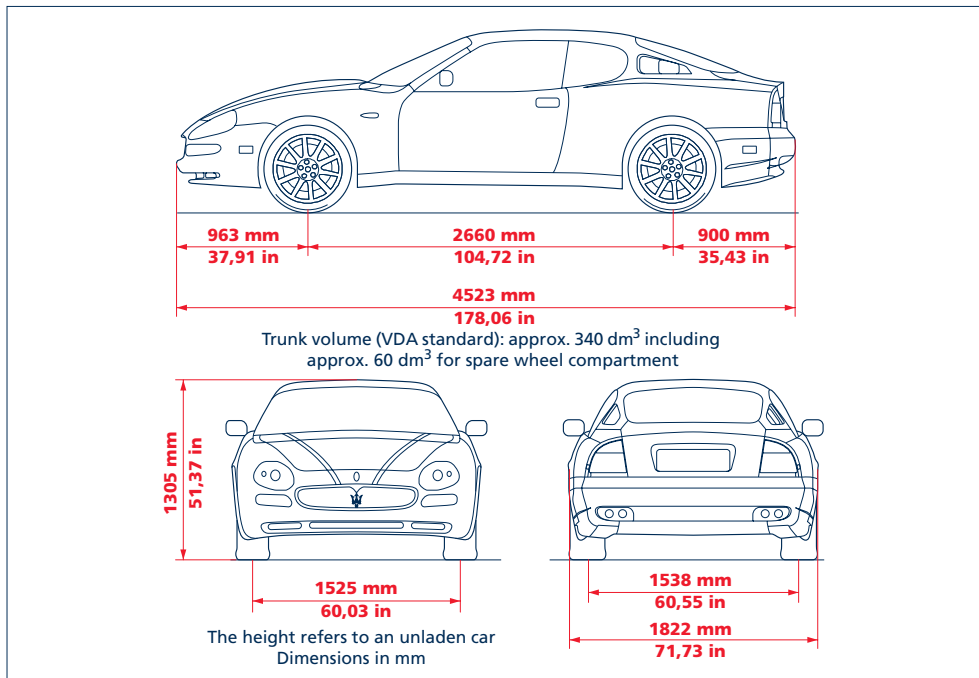

184

Technical specifications



## Tire pressure

Tire inflation pressure when cold (psi/  
bar).

	Rim size	Tire size	Tire brand	Inflation pressure when cold (psi)	Inflation pressure when cold (bar)
front	8" J x 18"	235/40 ZR18	MICHELIN PILOT SPORT TL	29 (up to 167 mph) 33 (over 167 mph)	2.0 (up to 270 km/h) 2.3 (over 270 km/h)
rear	9.5" J x 18"	265/35 ZR18	MICHELIN PILOT SPORT TL	29 (up to 167 mph) 33 (over 167 mph)	2.0 (up to 270 km/h) 2.3 (over 270 km/h)
* front	8" J x 18"	225/40 R18	MICHELIN PILOT ALPIN	29	2.0
			ASYMMETRIC PIRELLI WINTER 210	32	2.2
* rear	9.5" J x 18"	265/35 R18	MICHELIN PILOT ALPIN	29	2.0
			ASYMMETRIC PIRELLI WINTER 210	29	2.0
spare wheel (emergency wheel)	-	185/60-17 93P	VREDESTEIN	36	2.5

\* Winter tires



The maximum speed that can be reached with winter tires is indicated by the tire manufacturer. In any case, always comply with local regulations.

Only use winter tires of the prescribed dimensions and brand.



## Maintenance

Scheduled Maintenance	188
Additional checks	192
Level checks	193
Air filters	198
Anti-dust/anti-pollen filter	198
Battery	199
Electronic Control Units	201
Spark plugs	201
Wheels and tires	202
Windshield wipers	204
Air conditioning	205
Bodywork	205
Interiors	207
If the car is not used for long periods	208
Battery master switch	210





## Scheduled Maintenance

Correct maintenance is clearly the best way to maintain car performance and safety features, ensure respect for the environment and help lower operating costs.

**WARNING:** Also remember that the proper observance of the maintenance procedures is essential for maintaining warranty coverage.

For this reason, MASERATI has provided a series of checks and maintenance operations including the first service at 6,000 miles (10,000 km) and subsequently every 12,500 miles (20,000 km) up to 106,000 miles (170,000 km).

### Over 106 thousand miles (170,000 kilometers)

When 106,000 miles have been reached (170,000 kilometers), the scheduled maintenance restarts with the same operations provided for at 18,500 miles (30,000 km), than 31,000 miles (50,000 km), etc.

**WARNING:** The Scheduled Maintenance services are prescribed by the Manufacturer. Failure to have the services carried may invalidate the warranty.

The Scheduled Maintenance service is provided by **Authorized Maserati Dealers**. In the event that, when a service is performed, further replacements or repairs are found to be necessary in addition to the scheduled operations, these can be carried out only with the specific consent of the Customer.

**WARNING:** You are advised to notify your **Authorized Maserati Dealer** of any minor operating problems, without waiting for the next service.



### Main operations to be performed at the specified mileage

Main operations	Kilometres covered (in thousands)									
	10	30	50	70	90	110	130	150	170	
	Miles covered (in thousands)									
	6	18.5	31	43.5	56	68.5	81	93.5	106	
Belts for generator/water pump, ventilation compressor and hydraulic steering control	I-A	I*	I-A	I*	I-A	I*	I-A	I*	I-A	
	Replace at least every 3 years									
Engine oil and filter	R	R	R	R	R	R	R	R	R	
	Replace once a year									
Cooling system connections and lines	I	I*	I*	I*	I*	I*	I*	I*	I*	
Air filters		R*	R	R*	R	R*	R	R*	R	
Fuel injection connections and lines	I		I*		I		I*		I	
Ignition system cables and connections	I		I*		I		I*		I	
Spark plugs			R			R			R	
Active charcoal filter and Lambda sensors							R			
	Replace at least every 4 years									
Air injection system: lines and connection valves	I	I	I	I	I	I	I	I	I	
Blow-by system			I		I		I		I	
Fuel emission control system: lines, connections, seal and valves		I		I		I		I		
Differential and gearbox oil		I	R	I	I	R	I	I	R	
	Replace every two years									
"Cambiocorsa" gearbox system oil level	I	I	I	I	I	I	I	I	I	
	Check every year									
Hydraulic steering fluid level (drain if necessary)	I	I	I	I	I	I	I	I	I	
	Replace every 2 years									

I = Check and carry out any other necessary operation

A = Adjust

R = Replace

Scheduled Maintenance



Main operations	Kilometres covered (in thousands)									
	10	30	50	70	90	110	130	150	170	
	Miles covered (in thousands)									
	6	18.5	31	43.5	56	68.5	81	93.5	106	
Engine coolant level	I	I	I	I	I	I	I	I	I	I
	Replace every 2 years									
Brake/clutch fluid level (drain if necessary)	I	I	I	I	I	I	I	I	I	I
	Replace every year									
Brake system: lines, calipers, connections	I	I	I	I	I	I	I	I	I	I
Dashboard warning light efficiency	I	I	I	I	I	I	I	I	I	I
Handbrake operation	I	I	I	I	I	I	I	I	I	I
Wear condition of the braking elements (discs, pads); replace if necessary	I	I	I	I	I	I	I	I	I	I
Front and rear suspension joints and relative tightening	I	I	I	I	I	I	I	I	I	I
Steering system components, joint protection, rack boots on the steering wheel levers and on the axle shafts	I	I	I	I	I	I	I	I	I	I
Tightening of screws, nuts and bolts (including those for the exhaust system), couplings, retaining clips and clamps	I	I	I	I	I	I	I	I	I	I
Battery: connections and charge conditions	I	I	I	I	I	I	I	I	I	I
Air conditioning and heating system; compressor oil level	I	I	I	I	I	I	I	I	I	I
	Replace coolant and filter every 2 years									
Anti-pollen filter		R	R	R	R	R	R	R	R	R
	Replace every year. In the event of the car frequent use in dusty or strongly polluted environments, a more frequent replacement is recommended									
Starter motor and generator: power absorption and charge	I	I	I	I	I	I	I	I	I	I
Wheel alignment	I	I	I	I	I	I	I	I	I	I
I = Check and carry out any other necessary operation	A = Adjust			R = Replace						



Main operations	Kilometres covered (in thousands)									
	10	30	50	70	90	110	130	150	170	
	Miles covered (in thousands)									
	6	18.5	31	43.5	56	68.5	81	93.5	106	
Controls and adjustment systems in general, hinges, doors, hood/trunk	I	I	I	I	I	I	I	I	I	I
Correct operation and reliability of the seats and safety belts	I	I	I	I	I	I	I	I	I	I
Fastening screws and nuts on the bodywork	I		I		I		I		I	
Headlight aiming	I	I	I	I	I	I	I	I	I	I
Chassis and protected area integrity			I	I	I	I	I	I	I	I
	<b>Check every 2 years</b>									
Leather interiors treatment	I	I	I	I	I	I	I	I	I	I
Test the car on the road (any time this may be necessary)	I	I	I	I	I	I	I	I	I	I

I = Check and carry out any other necessary operation

A = Adjust

R = Replace

All the operations marked with and asterisk (\*) are not compulsory but rather recommended, in the event that the vehicle is frequently used in heavy-traffic conditions or on dusty or sandy roads.

The warranty concerning emissions and the Manufacturer's responsibility to recall the vehicle in case of problems shall not be invalidated if the Customer does not carry out the operations marked with the asterisk (\*).



## Additional checks

Every 300 miles (500 km) or before long journeys, check and if necessary restore:

- engine coolant level
- windshield washer fluid level
- tire pressure and condition.

### WARNING - Engine oil

If the car is used mainly in one of the following particularly severe conditions:

- dusty roads
- short (less than 5 miles/7-8 km) and repeated trips with outside temperature below 32 °F (0 °C)
- engine running frequently at idle speed without reaching a full speed operating temperature, the engine oil must be replaced more often than indicated in the Scheduled Maintenance plan.

### WARNING - Air filters

When using the car on dusty roads, replace the air filters more frequently than indicated on the Scheduled Maintenance plan.

Consult your **Authorized Maserati Dealer** if you have any doubts about the frequency for the engine oil and air filter replacements, in the relation to the car's conditions of use.

**WARNING: We strongly recommend that the maintenance of the vehicle must be carried out by your Authorized Maserati Dealer. For those routine and minor maintenance operations which you can carry out yourself, make sure that you always use the right equipment, original Maserati spare parts and the prescribed fluids; however, never carry out these operations if you have no experience.**



## Level checks

- 1) Engine oil
- 2) Engine coolant
- 3) Windshield washer fluid
- 4) Brake fluid and clutch hydraulic control
- 5) Power steering fluid

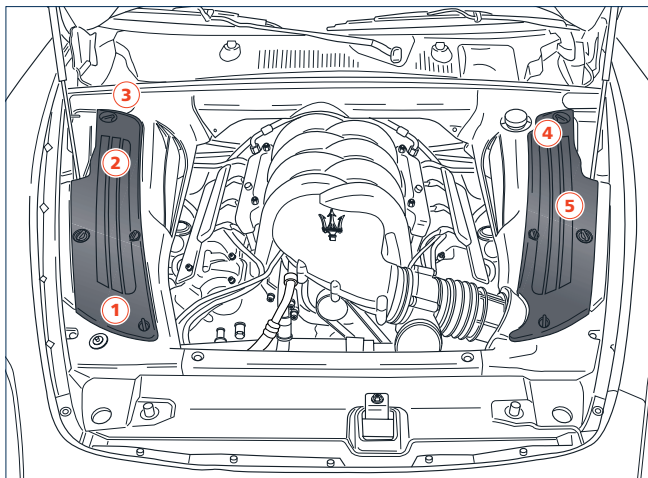



### Engine compartment panels

To check and top up the engine oil and coolant level, remove the right-hand covering panel **A** of the engine compartment.

To check and top up the brakes/hydraulic clutch control fluid and the power steering fluid, remove the left-hand covering panel **B** of the engine compartment.

To remove the engine compartment panels, rotate the fixing pins. To refit the panels, position them correctly then screw the tightening pins.

### Engine oil

The level checks must be carried out with the car on a level ground and with the engine warm idling. The oil level must be comprised between the **MIN** and **MAX** reference marks on the dipstick **C**. The gap between **MIN** and **MAX** corresponds to about 1 liter of oil.



**With the engine warm, be very careful when working inside the engine compartment: risk of burns! Remember that, with the engine warm, the electric fan could start to rotate: risk of injuries!**

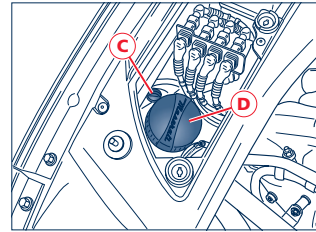
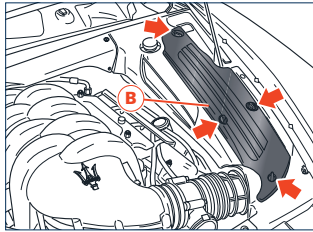
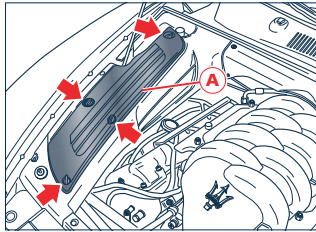

Level checks

If the oil level is near or even below the **MIN** reference mark, top up with oil pouring it through the filler cap **D** until reaching the **MAX** reference mark. The oil level should never exceed the **MAX** reference.

**WARNING:** Do not top up with oil having characteristics other than those of the oil already used in the engine.

After topping-up or replacing the oil, check the level once again.

**WARNING:** The engine oil used and the oil filter replaced contain substances that are dangerous for the environment. For replacing the oil and the filters you are advised to contact your **Authorized Maserati Dealer**, where all the necessary equipment is available to dispose of the used oil and filters in compliance with local regulations and in an environment-friendly manner.



**Used engine oil contains chemicals that have caused cancer in laboratory animals. Always protect your skin by washing thoroughly with soap and water.**

### Manual gearbox and "Cambiocorsa" gearbox oil

Consult your **Authorized Maserati Dealer** for the oil level check.

**WARNING:** Do not top up with oil having characteristics other than those of the oil already used in the engine.

**WARNING:** The gearbox waste oil contains substances that are dangerous for the environment. For replacing the oil, you are advised to contact your **Authorized Maserati Dealer**, where the necessary equipment is available to dispose of the used oil in compliance with local regulations and in an environment-friendly manner.

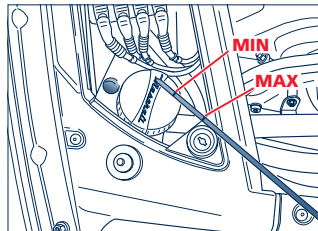



### Engine coolant

**!** **When the engine is very hot, do not remove the cap from the pan: risk of burns!**

To gain access to the pan, remove the right-hand panel of the engine compartment, following the instructions contained in the section "Engine compartment panels" (pag. 194). The fluid level must be checked when the engine is cold, and it must fall between the **MIN** and **MAX** references marked on the pan. If the level is too low, slowly pour the prescribed fluid through the filler neck, until the level is close to the **MAX** reference mark.

### Windshield/headlight washer fluid

For topping up, open the cap **E**, pull out the filler extension and pour in a mixture of water and detergent fluid in the percentages indicated on the product container.

**WARNING: If the temperature is below -4 °F (-20°C), use pure detergent fluid.**

**WARNING: Do not drive with the windshield washer reservoir empty: the use of washer fluid is essential for improving visibility.**

### Power steering fluid

**WARNING: Make sure that the power steering fluid does not come in touch with hot engine parts as it is flammable.**

To gain access to the reservoir, remove the LH panel of the engine compartment following the instructions contained in the section "Engine compartment panels" (pag. 194). With the car on a level ground and the engine cold, check that the fluid level corresponds with the **MAX** notch on the tank cap dipstick. To carry out the check, unscrew the cap, clean the dipstick, tighten the cap back, remove it again and check the level.

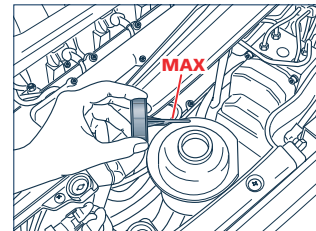
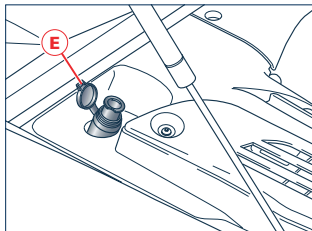
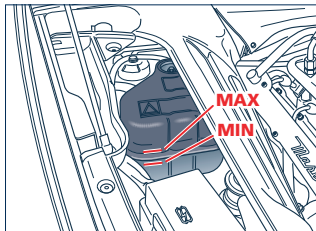

With the oil hot the level may also exceed the **MAX** notch. If necessary, top up with fluid making sure that it has the same characteristics as the one already used in the system.

### Brake and hydraulic clutch control fluid

To gain access to the reservoir, remove the LH panel of the engine compartment following the instructions contained in the section "Engine compartment panels" (pag. 194). Check that the fluid level in the reservoir is at the maximum level. If the level drops below the minimum, with the ignition key in the **MAR** position, the warning light "BRAKE" will light up on the instrument panel. To check the operation of the warning light bulb, press the center of the filler cap. If fluid is needed, use only the type classified as DOT4.

**WARNING:** The brake fluid is hygroscopic (i.e., it absorbs humidity). For this reason, if the car is used mainly in areas with a high rate of atmospheric humidity, the fluid should be changed more frequently than indicated in the Scheduled Maintenance Plan.

**WARNING:** Do not let the brake fluid, which is highly corrosive, come into contact with the paintwork. If this should happen, wash the paintwork immediately with water.

**WARNING:** The symbol  on the container identifies the synthetic type of brake fluid, distinguishing it from the mineral type. Using mineral fluids damages the special rubber linings of the brake system beyond repair.

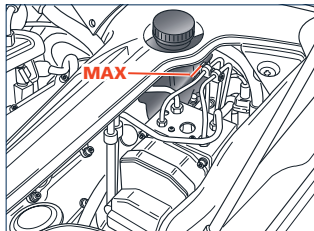



## Air filters

To replace the air filters, please contact your **Authorized Maserati Dealer**.

**WARNING:** Always replace both filters at the same time.

## Anti-dust/anti-pollen filter

This filter performs mechanical/ electrostatic air filtering, provided that windows and doors are closed properly.

Have your anti-dust/anti-pollen filter replaced at least once a year at your **Authorized Maserati Dealer**, preferably at the beginning of the summer period.

If the car is mainly used in the city traffic, on highways or dusty roads, we recommend to replace the filters more frequently than prescribed in the Scheduled Maintenance Plan.

**WARNING:** Failure to replace the filter may considerably reduce the air conditioning and heating system efficiency.



The anti-dust/anti-pollen filter replacement involves disassembling of the wiper blade arms, which have to be replaced after two disassembly operations.



The special arm fixing system provides for proper mechanical stability only after the first two refitting operations, provided that the specified tightening torque is observed.



We recommend therefore to have the anti-dust/anti-pollen filter, and consequently the windshield wiper blade arms, removed and replaced only at your **Authorized Maserati Dealer**.

## Battery

The battery fitted is of the “low maintenance” type, and is located on the right side of the luggage compartment.

To gain access to the battery, open panel **A**, which is fastened through a Velcro strap.

The battery fluid (electrolyte), with the car on a level ground, must always fall between the reference marks **MIN** and **MAX** on the battery.

In the event that the level is below the **MIN** reference mark, please contact your **Authorized Maserati Dealer** to have the system checked.

To recharge the battery, see the section “In an emergency” on page 168.



**The fluid contained in the battery is poisonous and corrosive. Avoid contact with the skin and eyes. Do not approach the battery with open flames or possible sources of sparks: risk of explosion and fire.**

Batteries contain substances that are very harmful for the environment. To replace the battery, please contact your **Authorized Maserati Dealer**, where the battery will be disposed of in full compliance with local regulations and in an environment-friendly manner.



**Battery posts, terminals and related accessories contain lead and lead compounds. Wash your hands after handling.**

**WARNING:** Incorrect assembly of electrical and electronic accessories can cause serious damage to the car.

**WARNING:** Before disconnecting the battery, lower the side windows by at least 1.5-2 in (4-5 centimeters), in order to avoid damaging the strips when opening and closing the doors. When the battery is connected and loaded, this operation is carried out automatically upon opening and closing the door. The windows must remain lowered until the battery is connected once again.

If the battery runs flat when the windows are fully raised, open the door only if necessary and taking utmost care. Do not close the door as long as the window cannot be lowered.

**WARNING:** Each time the battery is reconnected, wait at least 30 seconds with the ignition key in the “**MAR**” position before starting the engine so as to allow the electronic system which operates the motor-driven valves to perform the self-learning process. During this time it is essential not to activate any device.

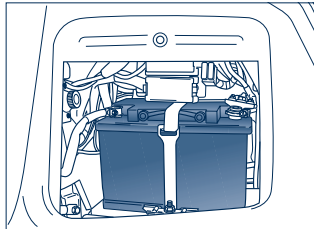
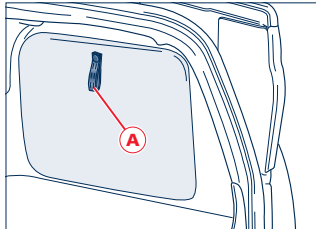



**WARNING:** Ventilation hose: The battery generates hydrogen gas, which is flammable and explosive. The battery is fitted with a ventilation hose which vents hydrogen gas out of the battery compartment through a ventilation opening in the bottom of this compartment. If the battery must be replaced, it is essential that the ventilation hose is properly connected to the battery and that it is routed through the ventilation opening provided (see illustration).

Be sure the ventilation hose is free of the debris. Only use replacement batteries equipped with a ventilation hose. Consult your local **Authorized Maserati Dealer**.

### **Useful hints for extending the life of the battery**

When parking the car, make sure that the doors, trunk, hood and flaps are properly closed. All interior lights should be off.

When the engine is turned off, do not keep the connected devices switched on for a long time (for example the radio, the hazard warning lights, the fan, etc.).

**WARNING:** If the battery charge remains below 50% for a long period of time, it will be damaged due to sulfating; its performance and starting power will be reduced and it will be more subject to freezing (this can happen even at 14 °F (-10 °C).

We recommend to have the battery charge condition checked, preferably at the beginning of the cold season, to prevent the electrolyte from freezing. This check should be carried out more frequently if the car is used mainly for short trips or if it is equipped with power absorbing devices that remain permanently on even if when the ignition key is removed. This applies especially if these devices have been fitted "after market".

If the car is not used for long periods of time, please refer to the section "If the car is not used for long periods" on page 208.

**WARNING:** If additional systems have to be fitted in the car, there is the risk of creating dangerous branches changes in the design of the original electric wiring.

## Electronic Control Units

No special precautions are required for the normal use of the car. In case of repairs to the electrical system or in an emergency starting, the following instructions must be strictly followed:

- Never disconnect the battery from the electrical system when the engine is running.
- Disconnect the battery from the electrical system when recharging it.

**WARNING:** When disconnecting the battery, first detach the negative terminal post (-) and then the positive one (+). When reconnecting the battery, first attach the positive terminal post (+) and then the negative one (-).

- Never carry out the emergency starting procedure using a battery charger: always use an auxiliary battery.
- Take special care when connecting the battery to the electrical system, checking both for correct polarity and for the connection efficiency.

- Never connect or disconnect the Electronic Control Units terminals when the ignition key is in the **MAR** position.
- Do not check the electric polarities through sparking.
- Disconnect the Electronic Control Units when carrying out electric weldings on the body. Remove them if the temperature is over 176 °F (80°C) (special interventions on the bodywork, etc.).

**WARNING:** Incorrect installation or modifications to the audio and alarm systems may interfere with the proper operation of the Electronic Control Units.

**WARNING:** Changes or repairs to the electrical system carried out in an incorrect manner or without taking into account the technical specifications of the system may cause operating anomalies with the risk of fire.

## Spark plugs

It is essential that the spark plugs are sound and clean for the engine to work efficiently and to ensure that polluting emissions are kept to a minimum level.

**WARNING:** The spark plugs must be changed at the intervals specified in the Scheduled Maintenance Plan. Only use the prescribed spark plugs.





## Wheels and tires



To obtain the best performances and the longest mileage from the tires, comply with the following precautions during the first 300 miles (500 Km):

- do not drive at maximum allowed speed
- drive on curves at low speed
- avoid sudden steering
- avoid sudden braking
- avoid sudden accelerations
- do not drive at high speed for a prolonged period of time.

### How to use the tires

**WARNING:** The tires must be constantly kept in good condition to ensure safe driving.

The tire inflation pressure must correspond to the prescribed values and should be checked only when the tires are cold, as the pressure increases as the tire temperature progressively rises.

Never reduce the pressure if tires are warm.

Insufficient tire inflating pressure can cause tire overheating and possible internal damages, which may even lead to the tire destruction.



**Check the tire inflating pressure at least every two weeks and before long trips.**

Impacts with curbs, holes and obstacles in the road, and prolonged trips on rough roads can cause tire damage which may not be visible to the naked eye.

Check your tires regularly for any signs of damage (e.g. scratches, cuts, cracks, bulges, etc.).

If sharp objects penetrate the tires, they can cause damage which is only visible when the tire is removed.

In any case, any possible damage must be inspected by an experienced tire fitter, as it may seriously reduce the tire life.

Remember that tires deteriorate with time, even if used little or not at all. Cracks in the tire tread and sides, and possible bulging, are a signs of deterioration.

 Have the old tires inspected by an experienced tire fitter, to make sure they can still be used safely. If the same tire has been on your car for 4 or 5 years, have it inspected by an experienced tire fitter.

 Never fit tires of uncertain origin.

 "Directional" tires have an arrow on their side showing the rolling direction. To keep the best performance when replacing a tire, make sure that the rolling direction corresponds to the one marked by the arrow.

 During the tire life the rolling direction of the first fitting shall always be observed, also in case of "non-directional" tires.

 Check the depth of the tire tread at regular intervals (minimum allowed value 0.063 in - 1.6 mm). The thinner is the tread, the greater is the risk of skidding.

 Drive carefully on wet roads to decrease the risk of aquaplaning.





## Windshield wipers

Clean the rubber parts regularly using the appropriate products.

Change the blades if the edge of the rubber is deformed or worn. In any case, the blades should be changed about once a year.



**Travelling with worn wiper blades is very dangerous because it reduces the visibility in the event of poor atmospheric conditions.**



**The arms of the wiper blade have to be replaced with new ones after two disassembling operations. The special arm fixing system helps provide for mechanical stability only after the first two refitting operations, provided that the specified tightening torque is observed.**



**It is therefore recommended to contact your Authorized Maserati Dealer for any intervention involving wiper arm disassembling (e.g., necessary to replacement of the dust/pollen filter).**

Some simple measures may reduce the possibility of damage to the blades.

- In the event of temperatures below 32 °F (0 °C), make sure that ice has not "glued" the wiper to the windshield. If necessary, release with an anti-ice product.
- Remove any snow deposited on the windshield: as well as protecting the blades, this avoids forcing and overheating the electric wiper motor.
- Do not activate windshield wiper when the windshield is dry.

### Spray nozzles

If the jet does not work, first check that there is fluid in the container (see "Level checks" in this chapter on page 193) then check that the nozzles are not clogged.

### Replacing the wiper blades

- 1) Raise the arm of the wiper blade slightly.
- 2) Push the blade as shown by arrow **A** to release it from the arm and then withdraw the blade.
- 3) Fit the new blade and secure it in the seat of the arm as shown by arrow **B**.

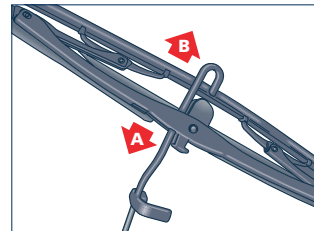
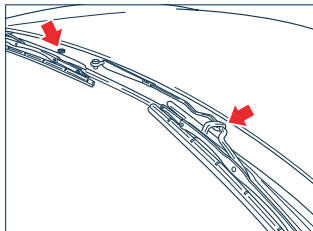

## Air conditioning

During the winter, the air conditioning system should be operated at least once a month for about 10 minutes. Before the summer season have the system efficiency checked by your **Authorized Maserati Dealer**.

**WARNING:** The system uses R134a type coolant that, in the event of accidental leakage, is not harmful for the environment. Under no circumstances should you use R12 fluid that, in addition to being incompatible with the system components, contains chloro-fluoro-carbons (CFCs).

## Bodywork

### Protection from atmospheric agents

The main causes of body corrosion are:

- atmospheric pollution
- salinity and humidity in the atmosphere (sea areas or humid climate)
- seasonal environmental conditions.
- salt used to remove snow/ice from roads.

The abrasive action of atmospheric dust and wind-carried sand, mud and stones should not be underestimated. On your car, MASERATI has adopted the best technological solutions to help protect the bodywork from corrosion.

The main measures are:

- Paint products and systems that provide the car with particular resistance against corrosion and abrasion.
- Use of galvanized (or pre-treated) body panels whose most exposed parts are highly resistant against corrosion.

- Spraying of the underbody, engine compartment, internal part of the wheelhouse and of other parts using highly protective wax products.
- Spraying of the plastic material most exposed parts with protective function: under the doors, inside part of the fenders, edges, etc.
- Use of ventilated box sections treated with wax products, to help prevent water condensation and stemming, which may lead to the internal formation of rust.

### Tips for keeping the bodywork in good condition

#### Paint

Paint does not only have an aesthetic function but also serves to protect the body panels. In the event of abrasions or deep scratches, we recommend to have the necessary touch-ups made immediately, to avoid any rust formation.

Touch-ups do not feature particular difficulties, even on metallic finishes. For all paint touch-ups, use only original products indicated on the plate applied on the engine compartment hood.





Normal paint maintenance consists in washing, the frequency of which depends on the conditions of use and of the environment. For example, in areas where there is high atmospheric pollution or the roads are spread with anti-freeze salt, it is advisable to wash the car more frequently.

**WARNING: Detergents pollute water. Therefore the car should be washed in areas equipped for the collection and purification of the fluids used for washing.**

For correct washing:

- Wet the bodywork with a low-pressure water jet.
- Run a sponge soaked in a neutral detergent solution over the bodywork, remembering to rinse the sponge frequently.
- Thoroughly rinse with water and dry with a jet of air or chamois.

When drying, take particular care with the parts that are less visible, such as the door bays, hood, headlight edges, in which water can be trapped more easily.

You are recommended not to take the car immediately into an enclosed environment, but leave it in the open air so as to allow the water to evaporate.

Do not wash the car after it has been left in the sun or when the hood is hot: the paint gloss could be affected. External plastic parts must be cleaned with the same procedure followed for the normal washing of the car. Avoid, as far as possible, parking the car under trees; the resinous substances that very often drop from the trees give the paint a dull appearance and increase the possibility of originating corrosive processes.

**WARNING: Bird droppings must be washed off immediately and thoroughly, since their acidity is particularly corrosive.**

**WARNING: To provide better protection for the paint, polish the car at intervals with a suitable product leaving a protective film on the paint.**

### **Windows**

To clean the windows use special detergents. Only use clean cloths so as not to scratch the windows or render them less transparent.

**WARNING: To avoid damaging the electrical resistors on the internal surface of the rear window, wipe it gently following the direction of the resistors.**

## Interiors

Check at regular intervals that there is no water trapped under the mats (due to drips off shoes, umbrellas etc.) which may cause the metal parts to oxidize.

### Cleaning the leather upholstery

- Remove the dried dirt with a slightly damp deerskin or a cloth, without rubbing too hard.
- Remove any liquid or grease stains with a dry absorbent cloth, without rubbing.
- Then run a soft cloth or deerskin damped with water and neutral detergent.
- If the stain persists, use specific products carefully following the instructions for use.

**WARNING:** Never use alcohol, alcohol-based products or solvents.

### Leather upholstery treatment

Have the leather upholstery only treated, as provided in the Scheduled Maintenance Plan, by your **Authorized Maserati Dealer** which has the required specific products.

### Briar wood parts

Remove any dirt with a deerskin leather or damp cloth.

**WARNING:** Do not use alcohol, gasoline or solvents to clean the instrument panel's and top's glass.



**Do not keep aerosol cans in the car. Risk of explosion. Aerosol cans should never be exposed to a temperature above 122 °F (50°C). The temperature inside the car when exposed to the sun may easily exceed this threshold.**





## If the car is not used for long periods

If the car has to stand idle for several months, take the following precautions:

- Wash and dry the car thoroughly.
- Park the car, in a covered, dry and possibly ventilated area.
- Engage a gear.

**WARNING:** Before disconnecting the battery, lower the side windows by at least 1.5-2 in (4-5 centimeters), in order to avoid damaging the strips when opening and closing the doors. When the battery is connected and loaded, this operation is carried out automatically upon opening and closing the door. The windows must remain lowered until the battery is connected once again. If the battery runs flat when the windows are fully raised, open the door only if necessary and taking utmost care. Do not close the door as long as the window cannot be lowered.

8

208

*If the car is not used for long periods*

- Disconnect the battery using the battery master switch found in the right-hand box of the luggage compartment (see on page 210).
- Check the battery charge condition. This check should be carried out monthly while the car is idle. Recharge the battery if the load-free voltage is below 12.5 V.
- Verify that the handbrake is not engaged.
- Clean and protect the painted parts applying protective waxes.
- Clean and protect polished metal parts with specific products available on the market.
- Talc the windshield wiper blades and raise them from the windshield.
- Cover the car with a long cloth in transpiring fabric (available at your **Authorized Maserati Dealer**). Do not use thick plastic sheets, which do not allow the humidity on the car surface to evaporate.
- Inflate the tires up to a pressure which must be 7.3 psi (+0.5 bar) higher than the normally prescribed one, and check it at regular intervals.



**The tire pressure must be brought back to the prescribed value before using the vehicle again.**

- Do not drain the engine cooling system.

### Restarting the car

Before restarting the car after a long period of inactivity, we recommend to carry out the following operations:



**Check the tires for pressure and for any damages, cuts or cracks. If this is the case, have them replaced.**

- Do not dry-rub the external surface of the car.
- Visually check if there are any fluid leaks (oil, brake and clutch fluid, engine coolant etc.).
- Have the engine oil and filter replaced.
- Check the fluid levels in the brake-clutch system, as well as the engine coolant level.
- Check the air filters and have them replaced if necessary.
- Check the condition of the engine belts.
- Reconnect the battery after having checked its charge condition.
- Release the door locks with the key.
- Reactivate the electronic alarm device pressing the remote control button once.

- Set the clock.
- Check that the seats work correctly: if not, carry out the "initialization" procedures described in the section "Seats" pg. 80, contained in the chapter " Before you drive ".
- With the gearshift in neutral, let the engine idle for several minutes pressing the clutch pedal repeatedly.



**This procedure must be performed outdoors. Exhaust gases contain carbon monoxide which is strongly toxic and potentially lethal.**





## Battery master switch

If the car is not used for long periods of time, we advise to disconnect the battery using the switch found to its left, on the right-hand side compartment of the trunk. To open the compartment, pull the cover using handle A.

Before disconnecting the battery:

- Make sure that the electronic alarm is not activated.

**WARNING:** Before disconnecting the battery, lower the side windows by at least 1.5-2 in (4-5 centimeters), in order to avoid damaging the strips when opening and closing the doors. When the battery is connected and loaded, this operation is carried out automatically upon opening and closing the door. The windows must remain lowered until the battery is connected once again. If the battery runs flat when the windows are fully raised, open the door only if necessary and taking utmost care. Do not close the door as long as the window cannot be lowered.

- Open the luggage compartment.
- Close the doors and lock them using the key (in order to avoid their being opened when the battery is disconnected).

**WARNING:** Disconnect the battery only several minutes after the engine has been switched off.

**WARNING:** When the battery is disconnected, some standard series systems or "after market" mounted systems could lose some of the data stored; in the event that a satellite alarm system is installed, remember to contact the Operative Headquarters before disconnecting the battery.

**WARNING:** When the battery is disconnected, the side window will not be lowered automatically upon opening the door. Therefore, closing the door without due care may cause the side window to break.

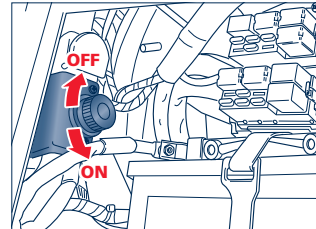
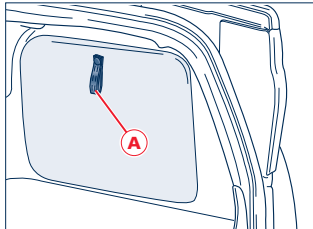

### Re-connecting the battery

- Open the luggage compartment with the key.
- Connect the battery.
- Release the door locks with the key.
- Reactivate the electronic alarm device pressing the remote control button once.
- Set the clock.
- Check that the seats work correctly: if not, carry out the "initialization" procedures described in the section "Seats" pg. 80, contained in the chapter " Before you drive " .

**WARNING:** Each time the battery is reconnected, wait at least 30 seconds with the ignition key in the "MAR" position before starting the engine so as to allow the electronic system which operates the motor-driven valves to perform the self-learning process. During this time it is essential not to activate any device.





## Conversion Table

<i>Distance</i>					
1 km	=	0,6214 mi	1 mi	=	1,609 km
1 m	=	3,2808 ft	1 ft	=	0,3048 m
1 m	=	1,0936 yd	1 yd	=	0,9144 m
1 cm	=	0,3937 in	1 in	=	2,54 cm
<i>Volume</i>					
1 l	=	0,2642 US gallon	1 US gallon	=	3,785 l
<i>Weight</i>					
1 kg	=	2,2046 lb	1 lb	=	0,4536 kg
<i>Power</i>					
1 kW	=	1,341 hp	1 hp	=	0,746 kW
<i>Pressure</i>					
1 bar	=	14,5 psi	1 psi	=	0,0689 bar
<i>Consumption</i>					
1 km/l	=	0,4251 mpg	1 mpg	=	2,3524 km/l

## Contents



9

Contents

213



Historical Background	4	General warnings regarding the seat belts	25	Parking lights/low beams	50
Introduction	6	Proper use of the seat belts	26	Directional indicators	50
Consulting the Manual	6	Proper transport of children	27	Airbag/pre-tensioner failure	50
Abbreviations	6	Front and side airbags	29	Light failure warning light	50
Updating	6	Front airbags	30	Electronic brakeforce distribution (EBD) failure warning light	50
Service	7	Passenger side airbag	31	Engine control system failure	
"Cambiocorsa" gearbox	7	Side airbags (side bags)	31	OBDII	51
NHTSA's Toll-free	7	General warnings	32	Catalytic converter high temperature warning light	51
Auto Safety Hotline	7	MSP System	34	Defective wheel anti-lock system (ABS)	51
Symbols	8	Activating the MSP system	34	Front brake pads worn/ brake fluid low	52
Danger symbols	8	Fault signals	34	Handbrake on	52
Symbols of prohibitions	8	ABS and EBD systems	35	Maserati CODE	52
Warning symbols	9	ASR system	37	Seat belts	52
Symbols indicating compulsory measures	9	(electronic anti-skid device)	37	Fuel shut-off inertia switch on	52
<b>General contents</b>	<b>11</b>	MSR function (engine braking torque adjustment)	37	Instruments and indicators	53
<b>Car identification data</b>	<b>13</b>	Parking sensors (optional)	38	1 – Oil pressure gauge	53
Identification plates	14	Sensors	39	2 – Coolant temperature gauge	53
Chassis marking	14	Sensor range	40	20 – Tachometer	53
Engine marking	14	Fault signals	41	18 – Voltmeter	54
Homologation plates	15	Fire extinguisher (optional)	42	19 – Fuel level gauge	54
Instructions plates	17	Fuel cut-off inertia switch	42	22 – Multi-function display	55
Key codes	18	Resetting the switch	42	23 – Doors and engine/luggage compartment open display	55
Electronic alarm device code	19	<b>Instruments and controls</b>	<b>43</b>	26 – Indicator for "Cambiocorsa" gear engaged / parking lights on	56
Rolling Code	19	Dashboard (version with "Cambiocorsa" gearbox)	44	27 – External temperature gauge	56
<b>Active and passive safety</b>	<b>21</b>	Dashboard (version with manual gearbox)	46	28 – Outside temperature LED	56
Seat belts	22	Instrument panel	48	Trip odometer reset button	57
Fastening the seat belts	22	Indicators and warning lights	50	Instrument panel dimmer switch	57
Front seat belt height adjustment	23	Seat heating (optional)	50	Controls and interior equipment	58
Load limiting devices	23	High beams	50		
Pretensioners	23				
Use of the rear seat belts	24				

Hazard warning lights	58	Operation	71	Side-view mirrors	85
Heated side window		Duplicating the keys	72	External side-view mirrors	85
and side-view mirror defroster	58	Emergency starting	72	Electrically-shaded interior	
Opening the luggage		Ignition switch	74	rear-view mirror	86
compartment	58	Electronic alarm device	75	Steering wheel	87
Opening the fuel tank flap	59	System activation	75	External lights and directional	
MSP system	59	Deactivation	76	indicators	88
SPORT setting	59	Exclusion of passenger		Light switch	88
Clock	60	compartment motion sensor		High beams	88
Front overhead lights	60	(ultrasound system)	76	Flashing the headlights	89
Rear overhead lights	61	Alarm memory	77	Parking lights	89
Sun visors	61	Market homologation	77	Directions indicators	89
Ashtray and cigarette lighter	61	Ordering extra radio operated		Windshield wipers and headlight	
Glove compartment	62	controls	77	washers (optional)	90
Center storage compartment	62	Replacing the Key radio control		Windshield wiper	90
Glass compartment	63	batteries	78	Intermittent operation-frequency	90
Seat pockets	63	Replacing "valet" key radio		Windshield washer	91
Coat-hooks	63	control batteries	79	Headlight washers (optional)	91
<b>Before you drive</b>	<b>65</b>	Front seats	80	Maserati Info Center	92
Doors	66	Back/forward adjustment	80	Controls	93
Opening doors from the outside	66	Height adjustment	80	Slot for navigator CD-ROM/audio	
From the inside	66	Seat angle adjustment	80	CD	96
Door open warning lights	66	Seat back angle adjustment	80	Rapid guide	96
Power windows	66	Lumbar support adjustment	80	Sound system	100
Door open indicator	67	Seatback tilt	81	Diversity system	101
Buzzer	67	Seat heating (optional)	81	High output stereo system	
Door courtesy light	67	Storing the seat and side rear		(optional)	101
Engine compartment hood	68	view mirror position (optional)	82	Air conditioning and heating	
Luggage compartment	69	System initialization	82	system	102
Fuel tank flap	70	Headrest	83	Upper dashboard outlet	
Fuel tank flap emergency		Armrest Center Storage		Central and side dashboard	
opening	70	compartment	83	vents	103
Keys	71	Rear seats	84	Front windshield pillar vents	103
The Maserati CODE system	71	Armrest	84	Lower dashboard vents	104
		Headrest	84		





Rear vents	104	DOWN for underrunning speed rate	118	Driving conditions	132
Automatic air conditioning and heating controls	105	Requesting neutral (N)	118	Before your trip	132
Equivalent temperature	105	Stopping the car	119	Capacities	132
Description of controls	106	Switching off the engine and the system	119	Safe driving	132
Description of operating strategies	107	Other system functions	119	Before you drive	132
"LOW BAT" Indicator	108	Using the brakes	122	Travelling	133
Dust/pollen air cleaner	109	Use of the engine	123	Driving at night	134
Specific luggage set (optional)	109	Breaking-in	123	Driving in the rain	134
<b>Using the vehicle</b>	<b>111</b>	Engine and transmission	123	Driving in fog	134
Starting the engine	112	Driving the car	123	Driving in the mountains	135
Procedure for manual gearbox version	112	Engine control system OBDII	124	Driving on snow or ice	135
Procedures for the "Cambiocorsa" gearbox	112	Constant speed control (Cruise Control)	125	Pollution control devices	136
How to warm up the engine after starting	113	General information	125	Other tips	137
Emergency starting with auxiliary battery	113	Controls	125	Parking	138
Starting with inertia maneuvers (push-start, etc.)	113	Storing a speed	126	Handbrake	138
Turning off the engine	113	Restoring the speed stored in the memory	126	Tires	139
Manual gearbox	114	Increasing the speed stored in the memory	126	Tire inflation pressure when cold	139
"Cambiocorsa" gearbox	115	Reducing a speed saved in the memory	127	Uniform Tire Quality Grading	139
Starting the ignition system	115	Resetting the speed stored in the memory	127	DOT Quality Grades	139
Operation with the engine switched off	116	Electronic suspension (optional)	128	Treadwear	139
Driving the car	116	Self-diagnosis	128	Traction	139
Hill Holder Strategy	117	Setting selection	129	Temperature	139
Up-shifting "UP"	118	Fault signals	130	Winter tires	140
UP for overrunning speed rate	118	Headlights	131	Snow chains	141
Downshifting "DOWN"	118	Headlight beam aiming	131	<b>In an emergency</b>	<b>143</b>
		Gas-emitting headlights (optional)	131	Emergency starting	144
				Toolkit	145
				If a tire gets a small puncture	146
				Precautions in the event of a small puncture	146
				Spare wheel	146
				(emergency wheel - optional)	147
				Refitting the standard wheel	151

If an exterior light goes out	152	<i>Recharging the battery</i>	168	<b>Maintenance</b>	187
<i>Front lights</i>	152	If you have to jack up the car	169	Scheduled Maintenance	188
<i>Rear lights</i>	152	<i>Using the jack</i>	169	<i>Over 106 thousand miles</i>	
<i>Directional indicator lights</i>	153	If you have to tow the car	170	<i>(170,000 kilometers)</i>	188
<i>Side marker lamp</i>	154	In the event of an accident	171	<i>Main operations to be</i>	
<i>Third stop light</i>	154	<i>If there are injured persons</i>	171	<i>performed at the specified</i>	
<i>License plate lights</i>	154	<b>Capacities and Technical</b>		<i>mileage</i>	189
If an interior light goes out	155	<b>Specifications</b>	173	Additional checks	192
<i>Front overhead lights</i>	155	Fuel	174	<i>WARNING - Engine oil</i>	192
<i>Rear overhead lights</i>	155	Engine oil	174	<i>WARNING - Air filters</i>	192
<i>Vanity mirror light</i>	156	Capacities: quantities		Level checks	193
<i>Glove compartment light</i>	156	and specifications of the products		<i>Engine compartment panels</i>	194
<i>Courtesy lights (below door)</i>	156	to be used	175	<i>Engine oil</i>	194
<i>Luggage compartment light</i>	157	<i>Recommended quantities</i>		<i>Manual gearbox and</i>	
If a fuse blows	158	<i>and products</i>	175	<i>"Cambiocorsa" gearbox oil</i>	195
<i>Replacing the fuses</i>	158	Fuel consumption	177	<i>Engine coolant</i>	196
<i>Position of fuses/relays</i>	158	<i>Fuel consumption</i>	177	<i>Windshield/headlight washer</i>	
<i>Fuse Color</i>	158	Technical specifications	178	<i>fluid</i>	196
<i>Maxi Fuse Colors</i>	158	<i>Engine</i>	178	<i>Power steering fluid</i>	196
<i>Fuses and relays under the</i>		<i>Injection – Ignition</i>	178	<i>Brake and hydraulic clutch</i>	
<i>dashboard, on the right hand</i>	159	<i>Lubrication system</i>	179	<i>control fluid</i>	197
<i>side</i>	159	<i>Cooling system</i>	179	Air filters	198
<i>Relays under the dashboard</i>	160	<i>Transmission</i>	179	Anti-dust/anti-pollen filter	198
<i>Fuses under the dashboard</i>	160	<i>Brakes</i>	181	Battery	199
<i>Fuses/relays in the engine</i>		<i>Suspension</i>	181	<i>Useful hints for extending</i>	
<i>compartment</i>	163	<i>Steering</i>	181	<i>the life of the battery</i>	200
<i>Side relay</i>	163	<i>Wheels</i>	182	Electronic Control Units	201
<i>Fuses on the rear panel</i>	164	<i>Performance</i>	183	Spark plugs	201
<i>Relay/fuse box units in the</i>		<i>Weights</i>	183	Wheels and tires	202
<i>luggage compartment</i>	165	<i>Dimensions</i>	184	<i>How to use the tires</i>	202
<i>Luggage compartment relays</i>	166	Tire pressure	185	Windshield wipers	204
<i>Luggage compartment fuses</i>	167			<i>Spray nozzles</i>	204
If the battery is fully discharged	168			<i>Replacing the wiper blades</i>	204
<i>Starting with the auxiliary</i>				<i>Air conditioning</i>	205
<i>battery</i>	168				





Bodywork	205
<i>Protection from atmospheric agents</i>	205
<i>Tips for keeping the bodywork in good condition</i>	205
Interiors	207
<i>Cleaning the leather upholstery</i>	207
<i>Leather upholstery treatment</i>	207
<i>Briar wood parts</i>	207
If the car is not used for long periods	208
<i>Restarting the car</i>	209
Battery master switch	210
<i>Re-connecting the battery</i>	211
<i>Conversion Table</i>	212
<b>Contents</b>	<b>213</b>
<b>Details to be recorded</b>	<b>219</b>

## Details to be recorded



**Owner**

---

---

---

**Address**

---

---

---

---

---

**Number plate**

---

**Registration no.**

---

**Engine identification no.**

---

**Paint identification no.**

---

**Code number of spare parts**

---

*Details to be recorded*

219

All the information contained in this manual is of a purely indicative nature since MASERATI car versions and models can be modified for either legal or commercial reasons without notice.

MASERATI does therefore reserve the right to make any modification to the cars described in this manual, at any time, for either technical or commercial reasons without notice.

Ask your MASERATI Dealer for any further information you may require.

For safety reasons and for the car best performance, as well as to preserve its original value, we recommend not to modify the vehicle equipment in such a way that may not correspond to the specifications contained in the provided homologation.

© 2003. Maserati North America, Inc.

Publication no. 67819100 - 1<sup>st</sup> edition - 07/2003

Printed by DECA s.r.l. Lugo - RA (Italy)

All rights reserved. This document must not be reproduced, even partially, without the written consent of Maserati S.p.A. and Maserati North America, Inc.

**Coordinamento Editoriale DECA s.r.l. Lugo - (RA) (Italy)**